

Model Name	Switch-M8eGLPWR+	Product Specification	401-28088-MY-SP02
Model No.	PN28088-MY		Page 1 of 10

1. Summary

Switch-M8eGLPWR+ is an Ethernet Switching Hub with management function having 8 ports of 10/100/1000BASE-T and two pairs of 10/100/1000BASE-T ports and SFP extension slot, one of which is selectable. Ports 1 to 8 support IEEE802.3at PoE power supply function.

2. Feature

- (1) Has wire-speed Layer 2 switching function.
- (2) Ports 1 to 8 are 10/100/1000BASE-T ports corresponding to auto negotiation. Also their speed and communication mode can be switched by configuration. Ports 9 and 10 can be used as a 10/100/1000BASE-T port corresponding to auto negotiation or an SFP extension slot exclusively.
- (3) Ports 1 to 8 can supply power conforming with IEEE802.3at. Supplying power up to 30 W per port, and up to 124 W in total is possible.
- (4) All twisted pair ports support straight/cross cable auto sensing function. Simply connect devices with straight cables, whether it is a terminal or a network device. (This function does not work if the port communication configuration is set at Fixed or Link Aggregation. Ports 1 to 8 are set at MDI-X. (default))
- (5) Telnet allows remote configuration changes and verifications of the Switching Hub. Remotely configure the PoE settings for each port (Ports 1 to 8).
- (6) Energy Efficient Ethernet (EEE) conforming to IEEE802.3az (LPI). When there is no data transmission at link up, the energy-saving state automatically starts so that power consumption can be reduced on each port.
- (7) Embedded power saving mode detects the connection status automatically and saves power consumption to minimum.
- (8) VLAN function allows free grouping of up to 256 VLANs.
- (9) The IEEE802.1w Rapid Spanning Tree Protocol is supported, allowing to build a system with redundancy.
- (10) The IEEE802.1p compatible QoS function is supported.
- (11) The IEEE802.1X compatible user authentication function (EAP-MD5/TLS/PEAP) is supported.
- (12) Has an Internet Mansion function, which ensures security between each door.
- (13) Due to the loop detection/shutoff function, a port where loop has occurred can be automatically shut off to prevent loop failures. When a port is shut off and recovered automatically, SNMP trap can be sent to notify the incident to the administrator. Moreover, the port with a loop can be identified by loop notification on the LEDs on the main unit and referring the history of loop on the setting screen.
- (14) The PoE scheduler function enables scheduling of PoE power supply control.
- (15) Supports ZERQUO assist Plus. Processes from introduction to maintenance can be performed easily.

Date issued	Dec. 14, 2015	Panasonic Eco Solutions Networks Co., Ltd.
Date revised	Feb. 22, 2016	

Model Name	Switch-M8eGLPWR+	Product Specification	401-28088-MY-SP02
Model No.	PN28088-MY		Page 2 of 10

3. Rated/Environmental Conditions

3-1. Power supply	AC100-240V, 50/60Hz, 2.6A (with a built-in power supply)
3-2. Power consumption	Normally, Max.158W (17.9W when not supplying power), Min.13.0W
3-3. Operating environment	Temperature: 0 - 50°C Humidity: 20 - 80%RH (no condensation)
3-4. Storage environment	Temperature: -20 - 70°C Humidity: 10 - 90%RH (no condensation)
3-5. EMC compliance	CISPR 22 Class A EN 55022 Class A EN 55032 Class A AS/NZS CISPR22 Class A VCCI Class A EN 61000-3-2, EN 61000-3-3 CISPR 24 EN 55024 IEC 61000-4-2, IEC 61000-4-3, IEC 61000-4-4, IEC 61000-4-5, IEC 61000-4-6, IEC 61000-4-8, IEC 61000-4-11
3-6. Safety compliance	IEC 60950-1 EN 60950-1
3-7. Environment compliance	RoHS compliant

4. Form

4-1. Form and materials/colors	Dimensions :44mm (Height) × 210mm (Width) × 260mm (Depth) (Excluding protruding sections) Case material :SECC Color : Main unit: Green 03, Front face: Black 03, Face plate label: Black 04
4-2. Mass (Weight)	2,200g

5. Hardware Specifications

5-1. Interface	<p>Twisted pair port 1-10 :RJ45 connector (*1) Transmitting and receiving network system: IEEE802.3 10BASE-T IEEE802.3u 100BASE-TX IEEE802.3ab 1000BASE-T</p> <p>Energy Efficient Ethernet (*2) :IEEE802.3az(LPI) Transmission speed :10/100/1000Mbps, full/half duplex Compatible cable :Twisted pair cable (At least equivalent to EIA/TIA568 category 5e)</p> <p>Maximum transmission distance :100m Auto-Negotiation :Communication speed and full/half duplex are automatically recognized. The setting can be fixed to 10Mbps, 100Mbps, or 1000Mbps and full duplex or half duplex.</p> <p>Up to 30 W of power can be supplied to ports 1 to 8.</p> <p>*1 Embedded power saving mode detects the connection status automatically and saves power consumption to minimum. *2 Energy Efficient Ethernet (EEE) conforming to IEEE802.3az (LPI). When there is no data transmission at link up, the energy-saving state automatically starts so that power consumption can be reduced on each port.</p> <p>SFP extension slot 9,10 SFF-8472 (DMI:Diagnostic Monitoring Interface) *Select either of RJ45 or SFP for use Optional Accessories :1000BASE-SX SFP Module (PN54021K-MY) 1000BASE-LX SFP Module (PN54023K-MY)</p>
----------------	---

Date issued	Dec. 14, 2015	Panasonic Eco Solutions Networks Co., Ltd.
Date revised	Feb. 22, 2016	

Model Name	Switch-M8eGLPWR+	Product Specification	401-28088-MY-SP02
Model No.	PN28088-MY		Page 3 of 10

5. Hardware Specifications

5-2. Switching mode	<p>Switching method :Store and Forward</p> <p>Switching capacity :20Gbps</p> <p>Packet transfer capability :Non-blocking Max 1,488,000pps/port (1000Mbps) Max 148,800pps/port (100Mbps) Max 14,880pps/port (10Mbps)</p> <p>MAC Address table :Max 8K entry/unit Automatic learning can be enabled/disabled for each port. Fixed registration is enabled.</p> <p>Buffer memory :512K Byte/unit</p> <p>Flow control :half-duplex Back pressure full-duplex IEEE802.3x</p> <p>Aging timeout :10 to 1,000,000 sec. (Default: 300 sec.)</p> <p>Jumbo frame supported :9KB</p> <p>Transmittable frames :EAP,BPDU</p>
5-3. Terminal emulator connection	<p>Console port :RJ45 connector 1 port</p> <p>Transmission mode :RS-232C (ITU-TS V.24)</p> <p>Emulation mode :VT100</p> <p>Communication configuration :9,600bps,8bit,None Parity control, Stop bit 1 bit</p>
5-4. LED display	<p>(1) POWER (Power) LED Green Light :Power is ON Off :Power is OFF</p> <p>(2) STATUS/ECO LED (Status/ECO mode) Green Light :Operating in status mode. Green Blink :Operating in ECO mode. All port LEDs (left) are turned off. Orange Light :Starting Orange Blink:Malfunction (Contact the seller)</p> <p>(3) PoE LIM. LED (PoE limit) Off Supplying power in the range from 0 to 109 W. Green Light : Supplying power in the range from 109 to 124 W. Orange Blink : A single port's power supply is exceeding the upper limit, or the total power supply of the Switching Hub is exceeding 124 W.</p> <p>(4) FAN LED (Fan sensor) Green Light : System is operating normally. Orange Blink : Fan fault is occurring.</p> <p>(5) TEMP LED (Temperature sensor) Green Light : The system is normally operating. Orange Blink : The temperature exceeded the set threshold of the internal temperature sensor. Set threshold of the internal temperature sensor: 70°C (factory default)</p> <p>(6) LOOP HISTORY LED (Loop History mode) Green Light : Operating in Loop History mode. Green Blink : Loop is occurring, or occurred within the last 3 days.</p>

Date issued	Dec. 14, 2015	Panasonic Eco Solutions Networks Co., Ltd.
Date revised	Feb. 22, 2016	

Model Name	Switch-M8eGLPWR+	Product Specification	401-28088-MY-SP02
Model No.	PN28088-MY		Page 4 of 10

5. Hardware Specifications

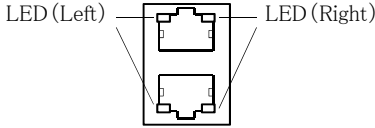
5-4. LED display	<p>(7) Port LED (left)</p> <p>Green light (when the LOOP HISTORY LED lamp is off) : Link is established at 10/100/1000 Mbps.</p> <p>Green light (when the LOOP HISTORY lamp is flashing) : Within three days after a loop has been eliminated</p> <p>Green flashing : Data is being sent/received at 10/100/1000 Mbps.</p> <p>Orange light : Shut off by the loop detection/shutoff function</p> <p>Off : No terminal is connected or the ECO mode is set.</p> <p>(8) Port LED (right)</p> <p>Green light : Power is supplied normally. (Ports 1 to 8 only)</p> <p>Orange flashing : Overload power supply (ports 1 to 8 only) or overload in a single port.</p> <p>Off : Power is not supplied or PoE receiving equipment is not connected.</p> <div style="text-align: center;">  </div>
5-5. Cascade connections	Displays the Auto MDI/MDI-X function settings. Ports 1-8 are set to "Disable," and Ports 9-10 are set to "Enable" at factory default setting.

6. Software Specifications

6-1. Configuration	Control parameters can be set by the following procedures: (1) Configuration from an asynchronous terminal connected to the console port. (2) Configuration from a remote terminal connected via TELNET and SSH (3) Configuration from a remote terminal via the Internet								
6-2. Switching Hub Control	Switching Hub can be controlled by the following procedures: (1) Control from an asynchronous terminal connected to the console port. (2) Control from a remote terminal using SSH/TELNET and TCP/IP network connection (3) Control using SNMP Manager The switching Hub operation status can be checked using the following functions. (1) Fan sensor function (2) Internal temperature sensor function (3) Function to display the CPU usage and memory usage (4) SFP module status checking function (DDM: Digital Diagnostic Monitoring)								
6-3. Rebooting	The system can be reset from the software in the following three modes: (1) Warm start (2) Reset to factory default (3) Reset items other than the IP address to factory default The reboot timer function can also be used in each mode.								
6-4. Supported Agent	<table border="0"> <tr> <td>Management protocol</td> <td>:SNMP v1/v2c (RFC1157,RFC1901)</td> </tr> <tr> <td></td> <td>TELNET (RFC854)</td> </tr> <tr> <td></td> <td>SSH v2 (RFC4251,RFC4252, RFC4253,RFC4254,RFC4716)</td> </tr> <tr> <td>Data transfer protocol</td> <td>:TFTP (RFC783)</td> </tr> </table>	Management protocol	:SNMP v1/v2c (RFC1157,RFC1901)		TELNET (RFC854)		SSH v2 (RFC4251,RFC4252, RFC4253,RFC4254,RFC4716)	Data transfer protocol	:TFTP (RFC783)
Management protocol	:SNMP v1/v2c (RFC1157,RFC1901)								
	TELNET (RFC854)								
	SSH v2 (RFC4251,RFC4252, RFC4253,RFC4254,RFC4716)								
Data transfer protocol	:TFTP (RFC783)								

Date issued	Dec. 14, 2015	Panasonic Eco Solutions Networks Co., Ltd.
Date revised	Feb. 22, 2016	

Model Name	Switch-M8eGLPWR+	Product Specification	401-28088-MY-SP02
Model No.	PN28088-MY		Page 5 of 10

6. Software Specifications

6-5. Supported MIB	RFC1213-MIB (MIB II) (RFC 1213) SNMPv2-MIB (RFC 1907) IP-FORWARDING-MIB (RFC 2096) only IpCidrRouteTable RMON-MIB (RFC 2819) Group 1,2,3,9 BRIDGE-MIB (RFC 1493) P-BRIDGE-MIB (RFC 2674) Q-BRIDGE-MIB (RFC 2674) IF-MIB (RFC 2233) other than IfTestTable RADIUS-AUTH-CLIENT- MIB (RFC 2618) POWER-ETHERNET-MIB (RFC 3621) deexSoppConfigTable, other thandotlxSuppStatusTable IEEE8021-PAE-MIB (IEEE802.1X MIB) IEEE8023-LAG-MIB (IEEE802.3ad MIB) RSTP-MIB
6-6. System log	Maximum number to be kept: 1024 Transfers system logs to the Syslog server (IPv4)
6-7. Loop detection	Turns on the port LED with a orange light when a loop occurs in the corresponding port. At this time, the relevant port automatically shuts down (default setting: 60 sec.) to prevent loop from occurring. During loop is occurring, or if loop has occurred within the latest 3 days, LOOP HISTORY LED blinks to notify this. · Loop detection setting Enabled (factory default setting) Enabled/disabled can be switched by configuring a setting using the console. The setting is kept even when the power is turned OFF. · Loop detection port Enabled: Ports 1 to 8 (factory default setting) Disabled: Ports 9 and 10 (factory default setting) · Loop shutoff time 60 to 86,400 sec. (Factory default setting: 60 sec.) The Set Time Port LED lights up orange and the port shuts off. · Loop history retention time 3 days The LOOP HISTORY LED lamp flashes for three days. The Port LED lamp also remains lit for three days after the loop is eliminated.
6-8. Others	Syslog Client (Transfers system logs to the Syslog server.) TFTP Client (Upgrades the software and saves/loads configuration information.) SNTP Client Login RADIUS (login authentication function by the RADIUS server) ZEQUO assist Plus PoE timer applications

Date issued	Dec. 14, 2015	Panasonic Eco Solutions Networks Co., Ltd.
Date revised	Feb. 22, 2016	

Model Name	Switch-M8eGLPWR+	Product Specification	401-28088-MY-SP02
Model No.	PN28088-MY		Page 6 of 10

7. Layer 2 Switching Functions

7-1. Spanning Tree	IEEE 802.1w Spanning Tree Protocol, Rapid Spanning Tree Protocol
7-2. VLAN	IEEE802.1Q Tag VLAN Protocol Port Base VLAN Number of VLAN registrations: 256 (including default) Internet Mansion function
7-3. Trunking	IEEE802.ad Link Aggregation function (LACP/Manual) Up to 5 groups can be created (up to 8 ports per group).
7-4. Port Monitoring	Traffic of the target port can be copied to the specified port and transmitted. (Two or more target ports can be specified.)
7-5. Multicast	IGMP Snooping (IGMP v1/v2) function Multicast filtering function
7-6. QoS	IEEE802.1p 4 levels of Priority Queue supported Scheduling Method: Priority Queuing (PQ:Strict priority queuing) Weighted Round Robin (WRR:Weighted round robin scheduling) DSCP Mapping function
7-7. Authentication Function	IEEE802.1X Port-based authentication EAP Packet Forwarding function (Enable/disable EAP transmission can be specified for each port.)
7-8. PoE power supply function	IEEE802.3at PoE power supply function. Up to 124 W of power can be supplied to ports 1 to 8 in total. (Maximum power supplied to a port: 30 W) Supply method :Alternative A(Cable signal lines 1, 2, 3, and 6 are used.)
7-9. PoE scheduler function	PoE power supply control can be scheduled. The setting can be configured by the month, week, day or specific date. The maximum number of schedules to be registered: 32
7-10. Ring protocol	Redundancy is enabled by ring configuration. (Up to one group can be registered.)

Date issued	Dec. 14, 2015	Panasonic Eco Solutions Networks Co., Ltd.
Date revised	Feb. 22, 2016	

8. WEB Browser-based Control (WEB control screen)

8-1. System Requirements																																			
8-1-1. WEB Browser	Microsoft Internet Explorer 11																																		
8-1-2. Runtime for Executing Java Applet	Java Runtime Environment (Ver. 1.4 and above)																																		
8-2. Configuration Function																																			
8-2-1. Switch Configuration	<table border="0"> <tr> <td>Administration Configuration</td> <td>Loop Detection Configuration</td> </tr> <tr> <td>IP Address Configuration</td> <td>DDM Configuration</td> </tr> <tr> <td>SNMP Configuration</td> <td>RRP Domain Management</td> </tr> <tr> <td>Port Configuration</td> <td>Ping Execution</td> </tr> <tr> <td>System Security Configuration</td> <td>Exception Handler</td> </tr> <tr> <td>ID/Password Change</td> <td>Watchdog Timer</td> </tr> <tr> <td>Forwarding Database(FDB) Configuration</td> <td>IGMP Snooping Configuration</td> </tr> <tr> <td>Time(SNTP) Configuration</td> <td>PoE Configuration</td> </tr> <tr> <td>VLAN Configuration</td> <td>Statistics</td> </tr> <tr> <td>Link Aggregation Configuration</td> <td>Software Update</td> </tr> <tr> <td>Port Monitoring Configuration</td> <td>Configuration File Transfer</td> </tr> <tr> <td>QoS Configuration</td> <td>System Reboot Configuration</td> </tr> <tr> <td>Storm Control Configuration</td> <td>System Log</td> </tr> <tr> <td>Static ARP Table</td> <td>Syslog Transmission Configuration</td> </tr> <tr> <td>LLDP Configuration</td> <td>Save Settings</td> </tr> <tr> <td>802.1X Access Control Configuration</td> <td></td> </tr> <tr> <td>Spanning Tree Configuration</td> <td></td> </tr> </table>	Administration Configuration	Loop Detection Configuration	IP Address Configuration	DDM Configuration	SNMP Configuration	RRP Domain Management	Port Configuration	Ping Execution	System Security Configuration	Exception Handler	ID/Password Change	Watchdog Timer	Forwarding Database(FDB) Configuration	IGMP Snooping Configuration	Time(SNTP) Configuration	PoE Configuration	VLAN Configuration	Statistics	Link Aggregation Configuration	Software Update	Port Monitoring Configuration	Configuration File Transfer	QoS Configuration	System Reboot Configuration	Storm Control Configuration	System Log	Static ARP Table	Syslog Transmission Configuration	LLDP Configuration	Save Settings	802.1X Access Control Configuration		Spanning Tree Configuration	
Administration Configuration	Loop Detection Configuration																																		
IP Address Configuration	DDM Configuration																																		
SNMP Configuration	RRP Domain Management																																		
Port Configuration	Ping Execution																																		
System Security Configuration	Exception Handler																																		
ID/Password Change	Watchdog Timer																																		
Forwarding Database(FDB) Configuration	IGMP Snooping Configuration																																		
Time(SNTP) Configuration	PoE Configuration																																		
VLAN Configuration	Statistics																																		
Link Aggregation Configuration	Software Update																																		
Port Monitoring Configuration	Configuration File Transfer																																		
QoS Configuration	System Reboot Configuration																																		
Storm Control Configuration	System Log																																		
Static ARP Table	Syslog Transmission Configuration																																		
LLDP Configuration	Save Settings																																		
802.1X Access Control Configuration																																			
Spanning Tree Configuration																																			
8-2-2. Time Configuration	SNTP Setting																																		
8-3. Monitoring Configuration																																			
8-3-1. General Information	System Information Setting : Display of detailed description (sysDescr) Display of contact (sysContact) Display of installation location (sysLocation) Display of host name (sysName)																																		

Model Name	Switch-M8eGLPWR+	Product Specification	401-28088-MY-SP02
Model No.	PN28088-MY		Page 8 of 10

9. Connector Pin Arrangement

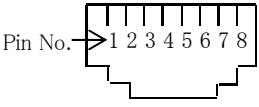
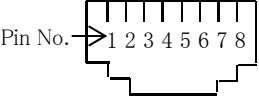
9-1. Port 1 - 10										
Status	Pin No.	1	2	3	6	4	5	7	8	
MDI-X	Signal	BLDB+	BLDB-	BLDA+	BLDA-	BLDD+	BLDD-	BLDC+	BLDC-	
MDI	Signal	BLDA+	BLDA-	BLDB+	BLDB-	BLDC+	BLDC-	BLDD+	BLDD-	
9-2. Console port										
Pin No.	Signal			Pin No.	Signal					
1	NC			5	GND					
2	NC			6	RXD					
3	TXD			7	NC					
4	GND			8	NC					

10. Installation Procedures and Accessories

10-1. Installation Procedures	(1) Mounting to rack	
10-2. Accessories	(1) Installation Guide	:1
	(2) CD-ROM	:1
	(3) Rubber foot	:4
	(4) Mounting bracket (for 19-inch rack)	:2
	(5) Connecting bracket	:2
	(6) Screw (for 19-inch rack)	:4
	(7) Screw (for fixing the main unit and the 19 inch rack mount bracket)	:8
	(8) Screw (for Connecting bracket)	:8
	(9) Power cord (BS1363)(*)	:1
		(*) The attached power cord is dedicated for AC 100 - 240 V use.

11. Optional Accessories

11-1. 1000BASE-SX SFP Module (Model No. :PN54021K-MY)	Fiber optic port connector type :LC connector (Duplex)
	Standards :IEEE802.3z 1000BASE-SX Transmission speed :1000Mbps, full duplex Compatible cable :Fiber cable 50/125 μm Multi Mode Fiber 62.5/125 μm Multi Mode Fiber Maximum transmission distance :550 m at 50/125 μm 220 m at 62.5/125 μm
11-2. 1000BASE-LX SFP Module (Model No. :PN54023K-MY)	Fiber optic port connector type :LC connector (Duplex)
	Standards :IEEE802.3z 1000BASE-LX Transmission speed :1000Mbps, full duplex Compatible cable :Fiber cable 10/125 μm Single Mode Fiber 50/125 μm Multi Mode Fiber 62.5/125 μm Multi Mode Fiber Maximum transmission distance :10 km when Single Mode Fiber is used 550 m when Multi Mode Fiber is used

Date issued	Dec. 14, 2015	Panasonic Eco Solutions Networks Co., Ltd.
Date revised	Feb. 22, 2016	

Model Name	Switch-M8eGLPWR+	Product Specification	401-28088-MY-SP02
Model No.	PN28088-MY		Page 9 of 10

12. Prohibitions when Using the Product to Guarantee Safety

The manufacturer assumes no responsibility for any problems occurring when the following conditions are not satisfied. Observe the following items when using the product.

- (1) Do not use power supply other than AC 100 – 240 V.
Deviation could lead to fire, electric shock, and/or equipment failure.
- (2) Do not handle the power cord with wet hand.
Deviation could lead to electric shock, and/or equipment failure.
- (3) Do not handle this Switching Hub and connection cables during a thunderstorm.
Deviation could lead to electric shock.
- (4) Do not disassemble and/or modify this Switching Hub.
Deviation could lead to fire, electric shock, and/or equipment failure.
- (5) Do not damage the power cord. Do not bend too tightly, stretch, twist, bundle with other cord, pinch, put under a heavy object and/or heat it.
Damaged power cord could lead to fire, short, and/or electric shock.
- (6) Do not put foreign objects (such as metal and combustible) into the opening (such as twisted pair port, console port), and/or do not drop them into the inside of the Switching Hub.
Deviation could lead to fire, electric shock, and/or equipment failure.
- (7) Do not connect equipments other than 10BASE-T/100BASE-TX/1000BASE-T to twisted pair port.
Deviation could lead to fire, electric shock, and/or equipment failure.
- (8) Do not place this Switching Hub in harsh environment (such as near water, high humid, and/or high dust).
Deviation could lead to fire, electric shock, and/or equipment failure.
- (9) Do not place this Switching Hub under direct sunlight and/or high temperature.
Deviation could lead to high internal temperature and fire.
- (10) Do not insert any modules other than the optional SFP modules (PN54021K-MY/PN54023K-MY) into the SFP extension slot.
Deviation could lead to fire, electric shock, and/or equipment failure.
For the latest information about compatible SFP extension modules, check our website.
- (11) Do not install this Switching Hub at the location with continuous vibration or strong shock, or at the unstable location.
Deviation could lead to injury and/or equipment failure.
- (12) Do not put this Switching Hub into fire.
Deviation could lead to explosion and/or fire.
- (13) Do not use the supplied power cord for anything other than this product.
Deviation could lead to fire, electric shock, and/or equipment failure.
- (14) Unplug the power cord in case of equipment failure.
Deviation, such as keeping connected for a long time, could lead to fire.
- (15) Connect this Switching Hub to ground.
Deviation could lead to electric shock, malfunction, and/or equipment failure.
- (16) Connect the power cord firmly to the power port.
Deviation could lead to electric fire, shock, and/or malfunction.
- (17) Unplug the power cord if the STATUS/ECO LED (Status/ECO mode) or TEMP LED (temperature sensor) , FAN LED (Fan sensor) blinks in orange (system fault).
Deviation, such as keeping connected for a long time, could lead to fire.

Date issued	Dec. 14, 2015	Panasonic Eco Solutions Networks Co., Ltd.
Date revised	Feb. 22, 2016	

Model Name	Switch-M8eGLPWR+	Product Specification	401-28088-MY-SP02
Model No.	PN28088-MY		Page 10 of 10

13. Prohibitions when Using the Product to Guarantee Safety

- (18) Up to two Switching Hubs can be connected by using the connection brackets and connection bracket screws .
Attach the connection brackets to the connection bracket screw holes on the front and back panels to securely fix the Switching Hubs before installation.
If the Switching Hubs are not fixed securely, they may fall, leading to injury and/or equipment failure.
- (19) Handle the Switching Hub carefully so that fingers or hands may not be damaged by twisted pair port, console port, or power cord hook block.
- (20) To connect a power receiving equipment supporting IEEE802.3at to this Switching Hub, use a cable rated Cat5e or higher.

14. Basic Instructions for the Use of This Product

- (1) For inspection and/or repair, consult the retailer.
- (2) Use commercial power supply from a wall socket, which is close and easily accessible to this Switching Hub.
- (3) Unplug the power cord when installing or moving this Switching Hub.
- (4) Unplug the power cord when cleaning this Switching Hub.
- (5) Use this Switching Hub within the specifications. Deviation could lead to malfunction.
- (6) Do not touch the metal terminal of the RJ45 connector, the modular plug of connected twisted pair cable.
Do not place charged objects in the proximity of them. Static electricity could lead to equipment failure.
- (7) Do not put the modular plug of the connected twisted pair cable on objects that can carry static charge, such as carpet.
Do not place it in the proximity. Static electricity could lead to equipment failure.
- (8) Do not put a strong shock, including dropping, to this Switching Hub.
Deviation could lead to equipment failure.
- (9) Before connecting a console cable to the console port, discharge static electricity, for example by touching metal appliance (do not discharge by touching this Switching Hub).
- (10) Do not store and/or use this Switching Hub in the environment with the characteristics listed below.
(Store and/or use this Switching Hub in the environment in accordance with the specification.)
 - High humidity. Possible spilled liquid (water).
 - Dusty. Possible static charge (such as carpet).
 - Under direct sunlight.
 - Possible condensation. High/low temperature exceeding the specifications environment.
 - Strong vibration and/or strong shock.
- (11) Please use this Switching Hub in place where ambient temperature is from 0 to 50°C.
Failure to satisfy the conditions above may result in a fire, electric shock, equipment failure, and/or malfunction.
Such events are not covered by the warranty. Do not block the ventilator of the Switching Hub.
Blocked ventilator induces the heat accumulation inside, causing equipment failure and/or malfunction.
If used at a temperature out of the operating temperature range, the protection equipment becomes activated and PoE power supply stops.
- (12) When using two Switching Hubs, do not stack them. When you place them side by side, allow for a space of 20 mm or more between them. This space is not necessary if you use supplied connection brackets.
- (13) Operation is not guaranteed if a module other than the optional SFP extension modules (PN54021K-MY/PN54023K-MY) is inserted into the SFP extension slot.
For the latest information about compatible SFP extension modules, check our website.

Date issued	Dec. 14, 2015	Panasonic Eco Solutions Networks Co., Ltd.
Date revised	Feb. 22, 2016	