

Model No. PN28080i-TH  
PN28080i-MY  
PN28080i-ID  
PN28080i-SG  
PN28080i-NZ

- Thank you for purchasing our product.
- This document provides important information about safe and proper operations of this Ethernet Switch.
- Please read the "**Important Safety Instructions**" on pages from 3 to 5.
- Any problems or damages resulting from disassembly of this Ethernet Switch by customers are not covered by the warranty.
- The instruction manuals (Menu Version, CLI Version, Web Version), latest firmware and SDN application (ZEQUO assist Plus) can be downloaded from the following URL.  
<https://panasonic.co.jp/ew/pewnw/english/datadownload/index.html>

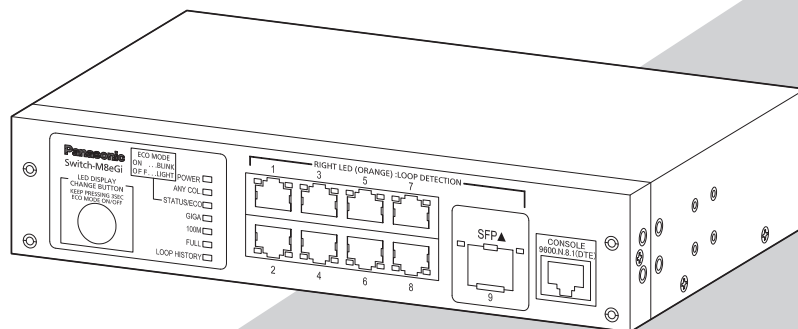

# Contents

Important Safety Instructions .....	3
Basic Instructions for the Use of This Product .....	6
1 Product Outline .....	7
1.1 Features .....	7
1.2 Specifications .....	8
1.3 Accessories .....	9
1.4 Basic operation .....	9
2 Part Names and Functions .....	10
2.1 LED display change .....	13
3 Installation and Configuration .....	15
3.1 Grounding Cable Connection .....	15
3.2 Mounting on a wall .....	16
3.3 Mounting to rack .....	17
3.4 Configuration of IP address (Basic) .....	18
Troubleshooting .....	20

# Important Safety Instructions

This chapter contains important safety instructions for preventing bodily injury and/or property damage. Please read carefully, and follow them at all times.

- Severity of bodily injury and/or property damage, which could result from incorrect use of the Ethernet Switch, are explained below.



## WARNING

This symbol indicates a potential hazard that could result in serious injury or death.



## CAUTION

This symbol indicates safety instructions. Deviation from these instructions could lead to bodily injury and/or property damage.

- The following symbols are used to classify and describe the type of instructions to be observed.



This symbol is used to alert users what they must not do.



This symbol is used to alert users what they must do.



## WARNING



- Do not use power supply other than AC 100 - 240 V.  
Deviation could lead to fire, electric shock, and/or equipment failure.
- Do not handle this Ethernet Switch and connection cables during a thunderstorm.  
Deviation could lead to electric shock.
- Do not disassemble and/or modify this Ethernet Switch.  
Deviation could lead to fire, electric shock, and/or equipment failure.
- Do not damage the power cord. Do not bend too tightly, stretch, twist, bundle with other cord, pinch, put under a heavy object and/or heat it.  
Damaged power cord could lead to fire, and/or electric shock.
- Do not handle the power cord with wet hand.  
Deviation could lead to electric shock, and/or equipment failure.
- Do not insert or drop any foreign objects, such as metal or combustible things into Ethernet Switches through the openings or twisted pair ports.  
Deviation could lead to fire, electric shock, and/or equipment failure.
- Do not store or use the Ethernet Switch in places where it might get splashed with liquids such as water, in places with a lot of humidity, in places with conductive dust, or in places where there are corrosive and combustible gases.  
Deviation could lead to fire, electrical shock, and/or equipment failure.
- Do not place this Ethernet Switch under direct sunlight and/or high temperature.  
Deviation could lead to high internal temperature and fire.
- Do not install this Ethernet Switch at the location with continuous vibration or strong shock, or at the unstable location.  
Deviation could lead to falling, injury and/or equipment failure.

## **WARNING**



- **Do not put the Ethernet Switch into fire.**  
Deviation could lead to explosion and/or fire.
- **If the device is going to be used in high temperature environments, do not perform the following operations with bare hands.**
  - Relocating the installation area, transporting, and attaching, and removing attachment brackets, etc.
  - Connecting and disconnecting twisted pair cables, fiber optic cables, SFP modules and console cables
  - Attaching, and removing power cords
  - Operating LED display change buttonsDeviation could lead to injuries or burns, etc. because of high temperatures.
- **Do not connect equipments other than 10BASE-T/100BASE-TX/1000BASE-T to twisted pair port.**  
**When connecting to a 10BASE-T device, use a Cat5 or above cable.**  
Deviation could lead to equipment failure.
- **Do not insert any other modules into the SFP extension slots (ports 9) except for our optional SFP modules (PN54022/PN54024).**  
Deviation could lead to equipment failure.  
Check our website for the latest information on supported SFP modules.

## **CAUTION**



- **Use the bundled power cord (AC 100 – 240 V specifications).**  
Deviation could lead to electric shock, malfunction, and/or equipment failure.
- **Unplug the power cord in case of equipment failure.**  
Deviation, such as keep connecting for a long time, could lead to fire.
- **Be sure to connect the ground cable.**  
Otherwise this might cause electrical shocks, misoperations and malfunctions.  
Connect the Ethernet Switch via the supplied power cord to the outlet which is connected to the ground.  
If the outlet is not connected to the ground, connect the ground cable (AWG18: green/yellow) to the ground terminal screw.
- **Connect the power cord firmly to the power port.**  
Deviation could lead to electric shock, fire, and/or malfunction.
- **If the STATUS (Status) LED blinks in orange (system fault), unplug the power cord since this is a malfunction.**  
Deviation, such as keep connecting for a long time, could lead to fire.
- **Handle the Ethernet Switch carefully to prevent fingers and hands from being damaged by twisted pair port, SFP extension slot, console port, or power cord hook block.**

# CAUTION



- **Up to two Ethernet Switches can be connected. When connecting two Ethernet Switches, use connection brackets and screws (for fixing the connection brackets) supplied with 19-inch rack mount brackets (two coupled units) to securely fix the connection brackets to the connection screw holes on the front and back panels, and then install the Ethernet Switches. If the Ethernet Switch is not fixed securely, injuries and/or malfunctions could be caused due to the Ethernet Switch falling, etc.**
- **Check whether the optical fiber cable connectors are contaminated with dust, etc.** This might cause the optical signal to not be transmitted normally, and cause misoperations and malfunctions. If they are contaminated, make sure to clean them off, then connect them to the optical fiber ports.
- **This Ethernet Switch is to be periodically serviced in order to maintain its performance.** Please assign a product administrator, and be sure to implement periodic maintenance. When doing maintenance, check the inspection chart that is posted on our website which has the requisite items listed on it.
- **When using this Ethernet Switch to design systems, use it after applying appropriate measures such as setting up redundant configurations.** Communication failures might be generated due to causes such as malfunctions or misoperations while the Ethernet Switch is being used.
- **When using this Ethernet Switch for applications which require extremely high reliability, be careful to expend all possible means to ensure safety and reliability.** This Ethernet Switch is not designed or manufactured with the intention that it be used for applications (in use with railways, aviation, and medical care, etc. where the influence rate due to communication failures is extremely high in regard to systems that directly affect systems and human lives) which require extremely high reliability.
- **Be aware of glitches which are caused in the usage environments such as age-related degradation, etc.** This may vary depending upon conditions such as utilisation rates and usage environments, but performance might decrease due to the age-related degradation, etc. of components. It is recommended that this Ethernet Switch be replaced about five years after it has been installed.
- **Be careful in regards to environmental restrictions whereby the Ethernet Switch can be used.** Please isolate the business power lines and communication lines. Isolate distribution lines and other distribution lines, and low current power lines, optical fiber cables, metallic water conduits, and gas conduits, etc. Noise may be generated in the communication lines which might cause communication glitches.
- **Be careful when performing the following operations since the device will be at high temperatures immediately after it has been energized or the power has been shut off.**
  - Relocating the installation area, transporting, and attaching, and removing attachment brackets, etc.
  - Connecting and disconnecting twisted pair cables, fiber optic cables, SFP modules and console cables
  - Attaching, and removing power cords
  - Operating LED display change buttonsDeviation could lead to injuries or burns, etc. because of high temperatures.

## Basic Instructions for the Use of This Product

- For inspection and/or repair, consult the retailer.
- Use commercial power supply from a wall socket, which is close and easily accessible to this Ethernet Switch.
- Unplug the power cord when installing or moving this Ethernet Switch.
- Unplug the power cord when cleaning this Ethernet Switch.
- Use this Ethernet Switch within the specifications. Deviation could lead to malfunction.
- Do not touch the twisted pair cable modular metal terminals which are connected to RJ45 connectors (twisted pair ports) or the connectors, nor place them near electrically-charged objects. Static electricity could lead to equipment failure.
- Do not put the modular plug of the connected twisted pair cable on objects that can carry static charge, such as carpet. Do not place it in the proximity. Static electricity could lead to equipment failure.
- Do not put a strong shock, including dropping, to this Ethernet Switch. Deviation could lead to equipment failure.
- Before connecting a console cable to the console port, discharge static electricity, for example by touching metal appliance (do not discharge by touching this Ethernet Switch).
- Do not store and/or use this Ethernet Switch in the environment with the characteristics listed below.  
(Store and/or use this Ethernet Switch in the environment in accordance with the specification.)
  - High humidity. Possible spilled liquid (water).
  - Dusty. Possible static charge (such as carpet).
  - Under direct sunlight.
  - Possible condensation. High/low temperature exceeding the specifications environment.
  - Strong vibration and/or strong shock.
- Please use this Ethernet Switch in place where ambient temperature is from 0 to 60°C. Failure to satisfy the conditions above may result in a fire, electric shock, equipment failure, and/or malfunction. Such events are not covered by the warranty.
- Do not block the ventilator of the Ethernet Switch. Blocked ventilator induces the heat accumulation inside, causing equipment failure and/or malfunction.
- If any module other than the optional SFP extension modules(PN54022/PN54024) is inserted into the SFP extension slot,operation is not guaranteed.For the latest information about compatible SFP extension modules,check our website.
- When using two Ethernet Switches, do not stack them. When you place them side by side, allow for a space of 20 mm or more between them.

1. Please note that Panasonic shall not bear any liability whatsoever for any damages (this shall include, but is not limited to, lost earnings, lost opportunities, etc.) which were generated in relation to damages caused by operations and usage, or the inability to use this Ethernet Switch, whereby the customer does not follow this Installation Guide.
2. The contents described in this document may be changed without prior notice. For the latest version, please refer to the Panasonic website.
3. For any question, please contact the retailer where you purchased the product.

# 1 Product Outline

Switch-M8eGi is an all Giga bit Ethernet Layer 2 Ethernet Switch with management function having 8 ports of 10/100/1000BASE-T and two pairs of 10/100/1000BASE-T port and SFP extension slot, one of which is selectable.

## 1.1 Features

- Has wire speed layer 2 switching functions.
- Fanless design solves noise problem or fan failure.
- Due to the loop detection/shutoff function, a port where loop has occurred can be automatically shut off to prevent loop failures. When a port is shut off and recovered automatically, SNMP trap can be sent to notify the incident to the administrator. Moreover, the port with a loop can be identified by loop notification on the LEDs on the main unit and referring the history of loop on the setting screen.
- Has a loop detection history function, which notifies when a loop occurs with the corresponding LED and enables a network administrator to identify the looped port after the loop is removed.
- Embedded power saving mode detects the connection status automatically and saves power consumption to minimum.  
Factory default : Disable
- Power consumption can be suppressed by switching off the port LEDs (left) via the ECO mode LED functions.
- Ports 1 to 8 are auto negotiation-ready 10/100/1000BASE-T ports. Their speed and communication mode can be changed by configuration.  
Port 9 can be exclusively used as an SFP extension slot.
- All twisted pair ports support straight/cross cable auto sensing function. Simply connect devices with straight cables, whether it is a terminal or a network device. (This function does not work if the port communication configuration is set at Fixed or Link Aggregation. Ports 1 to 7 are set at MDI-X. (default))
- IEEE802.1Q VLAN tagging is supported, and a maximum of 256 VLANs can be registered.
- The IEEE802.1p compatible QoS function is supported.
- Has an Internet Mansion function, which ensures security between each door.
- Has a port grouping function, which groups ports that are allowed to communicate with one another to limit communications between different groups.
- Equipped with energy efficient Ethernet (EEE) conforming to IEEE802.3az(LPI). When there is no data transmission at link up, the energy-saving state automatically starts so that power consumption can be reduced on each port.  
Factory default : Disable
- The IEEE802.1X compatible user authentication function (EAP-MD5/TLS/PEAP) is supported.
- Each single port supports IEEE 802.1X, Web, and MAC authentication protocols, eliminating the need for individually setting the ports' authentication parameters.
- Supports ZEQUO assist Plus. Processes from introduction to maintenance can be performed easily.

# 1 Product Outline

## 1.2 Specifications

<b>Interface</b>	Twisted pair port 1-8:RJ45 connector Transmitting and receiving network system IEEE 802.3 10BASE-T IEEE 802.3u 100BASE-TX IEEE 802.3ab 1000BASE-T Energy Efficient Ethernet function IEEE 802.3az(LPI) SFP extension slot port 9 Transmitting and receiving network system IEEE 802.3z 1000BASE-X Note: Can be used as an SFP exclusively SFF-8472 (DMI:Diagnostic Monitoring Interface) Console port:RJ45 connector RS-232C(ITU-TS V.24)
<b>Switching mode</b>	Store and Forward method: Forwarding rate 10BASE-T: Max. 14,880 pps/port 100BASE-TX: Max. 148,800 pps/port 1000BASE-T/1000BASE-X: Max. 1,488,000 pps/port MAC Address table: Max. 8K entry/unit Buffer: 512K Bytes/unit *EAP frame,BPDU frame transmission
<b>Link aggregation</b>	IEEE802.3ad Link aggregation function (STATIC) Configurable up to 5 groups (Max. 4 ports per group)
<b>VLAN</b>	IEEE802.1Q tagging VLAN (256 groups max.) Port based VLAN, Internet mansion function
<b>QoS</b>	IEEE802.1p compatible, Supports 4 priority queues
<b>Port monitoring</b>	1:n
<b>Port grouping functions</b>	Communication control is available only for ports in the same group. (Up to 256 groups can be registered.)
<b>Management method</b>	ZEQUO assist Plus, SNMP v1/v2c/v3, Telnet, SSH (v2), WEB, CLI
<b>Loop detection</b>	Ports 1-7: ON, Ports 8, 9: OFF (default setting) Port shut-off time: 60 -86400 sec (default setting is 60 sec) Port history hold time: 3 days
<b>Other</b>	Supports the IEEE802.1X authentication(MAC-based, port-based) MAC authentication, WEB authentication, Triple authentication Storm control function, multi-cast address group registration function, DDM function, IPv6 supported
<b>Power supply</b>	AC 100-240 V, 50/60 Hz, 0.5 A
<b>Power consumption</b>	Normally, Max. 6.2 W, Min. 2.4 W
<b>Operating environment</b>	Temperature: 0-60°C, Humidity: 20-80% RH (no condensation) (Warning) Failure to satisfy the conditions above may result in a fire,electric shock,equipment failure,and/or malfunction. Such events are not covered by the warranty.
<b>Storage environment</b>	Temperature: -20-70°C, Humidity: 10-90% RH (no condensation)
<b>Fan</b>	Not installed
<b>External dimensions</b>	44 mm (Height) × 210 mm (Width) × 130 mm (Depth) (Excluding protruding sections)
<b>Mass (Weight)</b>	1,100g

\*For detailed specifications, refer to the product' s specifications.

## 1.3 Accessories

Please be sure to confirm the content.

Please contact our distributor if any of the contents are insufficient.

Quantity

- Installation Guide (this document) ..... 1 (\*)
  - Rubber foot ..... 4
  - Wall mount bracket ..... 2
    - Screw (for fixing the wall mount brackets to the Ethernet Switch) ..... 8
  - Rack mount bracket (for 19-inch rack) ..... 2
    - Screw (for 19-inch rack) ..... 4
    - Screw (for fixing the mount brackets to the Ethernet Switch) ..... 8
  - Connection bracket (for connecting two Ethernet Switches) ..... 2
    - Screw (for fixing the connection bracket) ..... 8
  - Power cord ..... 1
- \* Just the PN28080i-TH has 1 Installation Guide in Thailand (a total of 2 guides).

[Power Cord]

The following power cords are supplied as per the intended nation of delivery.

Product Number	Locale	Power Cord Rating	FUSE Rated Current	Plug Type
PN28080i-TH	Thailand	250 VAC 6 A	-	TIS166-2549
PN28080i-MY	Malaysia	250 VAC 10 A	13 A	BS1363
PN28080i-ID	Indonesia	250 VAC 10 A	-	CEE7/7
PN28080i-SG	Singapore	250 VAC 5 A	5 A	BS1363
PN28080i-NZ	Australia New Zealand	250 VAC 10 A	-	AS/NZS 3112

[Optional accessories]

- PN54022-XX 1000BASE-SX SFP Module (i)
- PN54024-XX 1000BASE-LX SFP Module (i)

The XXs are identical to the intended nation of delivery codes.

## 1.4 Basic operation

This Product does not have a power ON/OFF switch. Connect the supplied power cord to this Ethernet Switch and connect the other end into an electric outlet.

This Ethernet Switch operates at AC 100 - 240 V (50/60 Hz).

When power is supplied, all the LEDs are turned ON.

Then, PWR LED (Power) lights in green, STATUS/ECO LED (Status/ECO mode) lights in orange, and self-diagnosis of hardware is executed.

On completion of self-diagnosis, PWR LED (Power) and STATUS/ECO LED (Status/ECO mode) light in green, and the Ethernet Switch starts operation as a Ethernet Switch.

When this Ethernet Switch successfully communicates with a terminal connected to a port, the Port LED lights up.

When the terminal is not operating normally, for example when power is not supplied to the terminal, the Port LED does not light up.

When the Eco mode is set, Port LED lamps do not light up.

**\* For configuration and management method, please see the PDF version of the Operating Instructions on Panasonic's website.**

## 2 Part Names and Functions

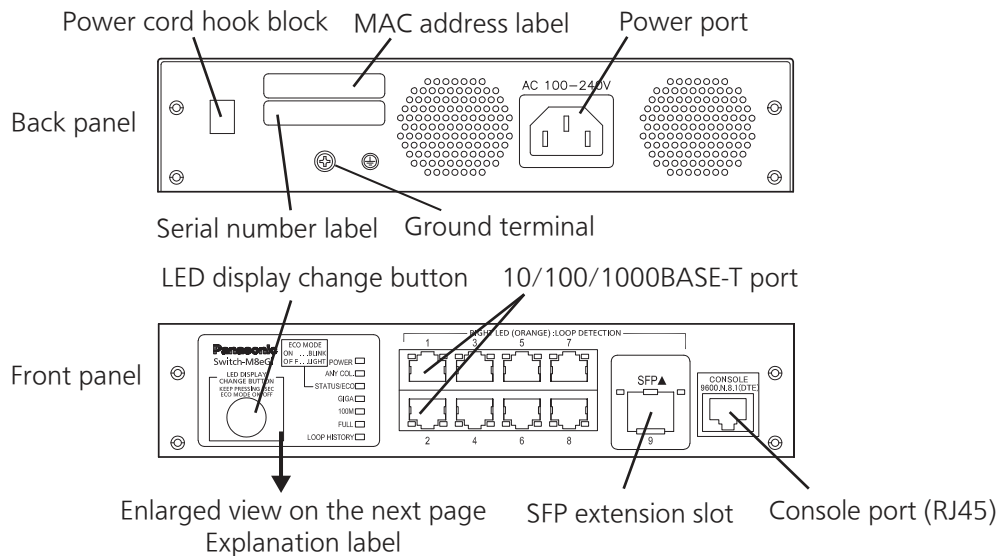

- **Power port**

Connect the supplied power cord to this port and connect the other end into an electric outlet.

- **Power cord hook block**

If the supplied power cord is hanged to this block, the cord becomes hard to pull out from the power port.

- **Ground terminal**

Only qualified personnel should install minimum 18AWG green-and-yellow stranded copper wire to Ground terminal screw.

- **10/100/1000BASE-T port (ports 1–8)**

Devices such as 10/100/1000BASE-T terminal, hub, repeater, bridge, and Ethernet Switch can be connected to this port. Install the device so that the length of twisted pair cable (CAT5e or above) becomes 100 m or less.

- **SFP extension slot (port 9)**

Install SFP extension module here.

SFP port supports only the full duplex communication.

- **Console port**

Transmission mode	: RS-232C	Emulation mode	: VT100
Transmission speed	: 9,600 bps	Data length	: 8 bits
Stop bit	: 1 bit	Parity control	: None
Flow control	: None	Transmission connector	: RJ45

Use our optional RJ45-DSub 9-pin console cable for the console cable.

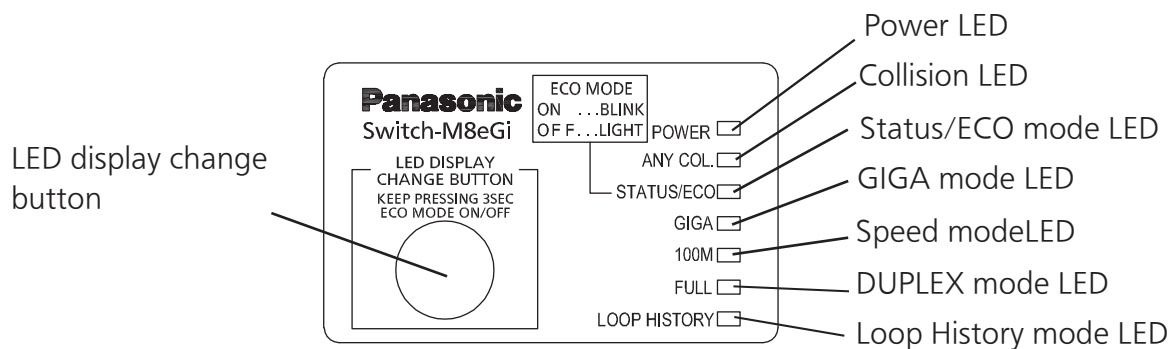

- **POWER (Power) LED**

Green Light : Power is ON.  
Off : Power is OFF.

- **ANY/COL. (Collision) LED**

Orange Light : During half-duplex operation, packet collision is occurring in either port.

- **STATUS/ECO (Status/ECO mode) LED**

Green Light : Operating in status mode.  
Green Blink : Operating in ECO mode.  
All Port LEDs (left) are turned off.  
Orange Light : Starting up  
Orange Blink : Malfunction (Contact the shop.)  
Off : Power is OFF.

- **GIGA (GIGA mode) LED**

Green Light : Operating in GIGA mode.

- **100M (Speed mode) LED**

Green Light : Operating in Speed mode.

- **FULL (DUPLEX mode) LED**

Green Light : Operating in DUPLEX mode.

- **LOOP HISTORY (Loop History mode) LED**

Green Light : Operating in Loop History mode.  
Green Blink : Loop is occurring, or occurred within the last 3 days.

## 2 Part Names and Functions

Table1. Ports and Port LED lamps 1 to 9 correspond as shown below.

Port LED	Display mode	Behavior	Description
Left	STATUS/ECO	Green Light	Link is established.
		Green Blink	Transmitting and receiving data.
		Off	No device connected.
	GIGA	Green Light	Link is established at 1000 Mbps.
		Off	Link is established at 100 Mbps or 10 Mbps, or no device is connected.
	100M	Green Light	Link is established at 100 Mbps.
		Off	Link is established at 1000 Mbps or 10 Mbps, or no device is connected.
	FULL	Green Light	Link is established at full-duplex.
		Off	Link is established at half-duplex or no device is connected.
	LOOP HISTORY	Green Light	Loop has been detected within the last 3 days.
Off		No loop detection history.	
Right	-	Orange Light	Shutting down by loop detection.
		Off	Not shutting down by loop detection.

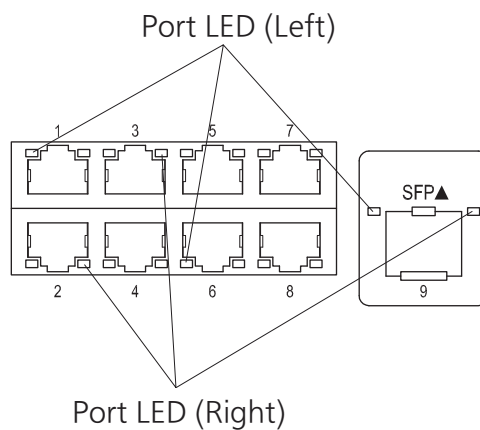

## 2.1 LED display change

### ●Display style set by the LED display change button

Indication on the front panel and LED lamps

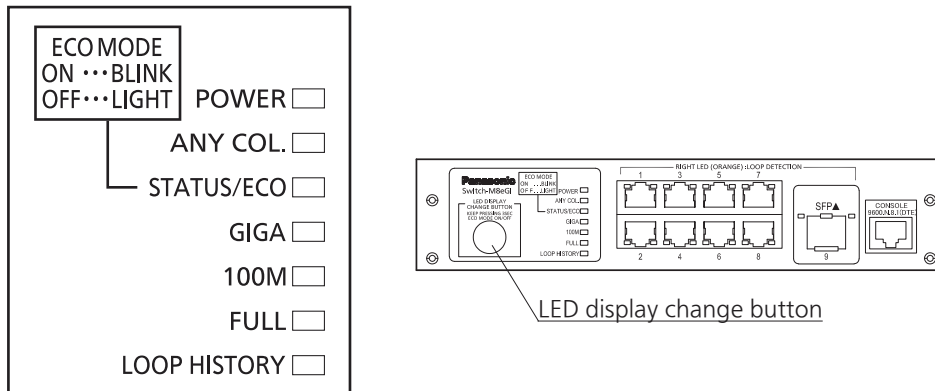

You can display the following items using the LED display switch button. Display for the connection with a connected terminal (Status mode), Display for the 1000 Mbps transmission rate (GIGA mode), Display for the 100Mbps or 10 Mbps transmission rate (Speed mode), Display for the full-duplex or half-duplex transmission system (DUPLEX mode), Display for ports with a loop history (Loop history mode), All port LED lamps can be turned OFF (ECO mode).

### ●Two types of Base modes and each mode

The mode at the start is called "Base mode."

There are two types of Base modes: Status mode (factory default setting) and ECO mode. You can change the Base mode by holding down the LED display switch button (for at least 3 sec).

When the Base mode is changed normally, all STATUS/ECO, GIGA, 100M, and FULL LED lamps light up at the same time. When you release the button, the Base mode is changed to the selected mode.

If the mode is changed to the GIGA mode, Speed mode, DUPLEX mode, or loop history mode and the LED display switch button is not used for one minute or longer, the mode automatically returns to a Base mode (Status mode or ECO mode). The Base mode is maintained even after the power is turned OFF.

## 2 Part Names and Functions

Switch two types of Base modes and their LEDs in the following way:

When Base mode is Status mode (factory default setting)

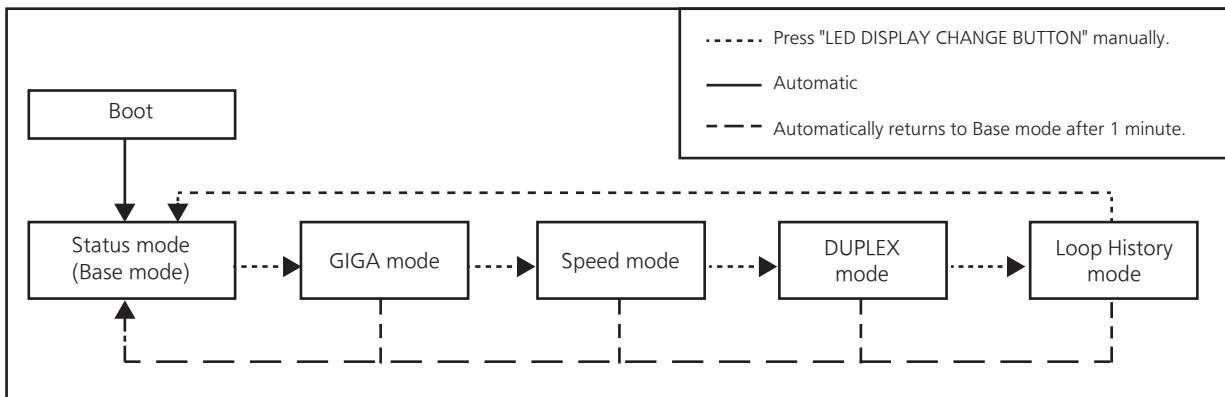

When Base mode is ECO mode



Switch Base mode (keep pressing "LED DISPLAY CHANGE BUTTON" over 3 seconds)

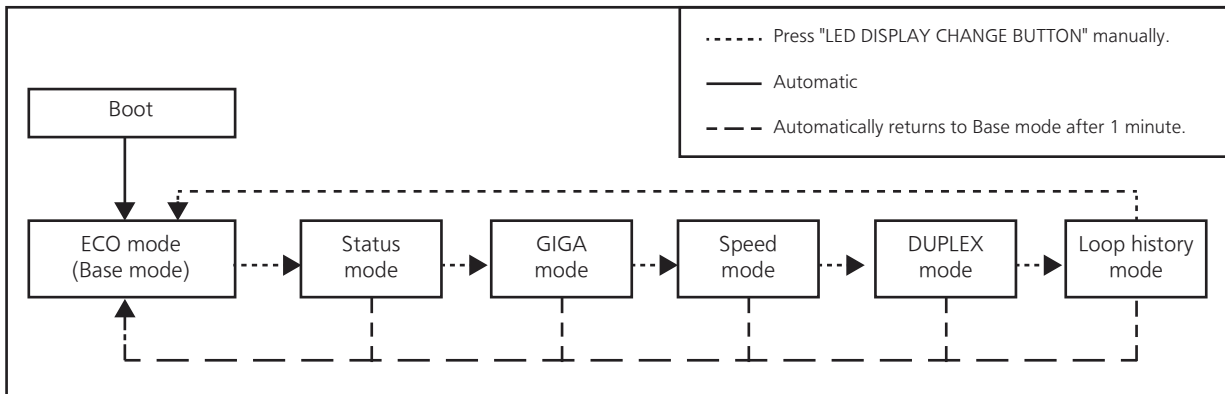

※The Base mode is maintained even after the power is turned OFF.

LED lamps for each mode and LED lamps for ports 1 to 9 correspond as shown in Table 1 (see page 12).

### ●Loop detection/shutoff function and loop history function

Turns on the port LED with a orange light when a loop occurs in the corresponding port. The Loop shutoff mode has the following 2 types of modes.

- Block mode (factory default)

When loops are detected, the port statuses are automatically blocked, and just the specified packets which include the loop detection packets will be transmitted and received.

- Shut-down mode

When loops are being detected, the ports will be automatically linked down, and none of the packets will be transmitted and received.

\*Just the loop detection packets from 30 seconds before the set recovery time will automatically be transmitted and received.

While loop is occurring, or if loop has occurred within the latest 3 days, LOOP HISTORY LED blinks to notify this. It is possible to switch loop detection setting (OFF/ON) by using a console cable (for detail, see the PDF version of the Operating Instructions). The default setting is ON.

If you wish to clear LOOP HISTORY LED, turn OFF once the power supply of the Ethernet Switch and turn it ON again.

Then, loop detection history is deleted.

The Ethernet Switch can hold up to 64 loop history logs.

# 3 Installation and Configuration

## 3.1 Grounding Cable Connection

The chassis of the equipment must be grounded properly so that the lightning can flow to the ground, which improves the capability of the chassis for resisting the electromagnetic interference.

1. Ensure that the grounding cable is connected correctly so that the equipment is protected against lightning and interference. The correct connection of the grounding cable is an important measure to ensure the human safety.
2. Connect the chassis to the ground by using a grounding cable. The grounding resistance must be smaller than 0.10 ohms and the gauge of the grounding cable must be no less than 18 AWG and the length is 50 cm.
3. The ground installed screw shall comply with 3.5mm minimum in nominal thread diameter, and engage at least two complete threads into metal chassis with appropriate fixing hardware like washer.
4. The grounding cable shall not be removed during normal operation, servicing or maintenance.
5. Installation steps:  
Step 1: Ensure the detachable power supply cord is removed.  
Step 2: Use the screwdriver to turn the screws on the earth ground screw point.  
Step 3: Strip one end of the ground wire to the ground hole of system.  
Step 4: Connect the other end of the ground wire to a suitable grounding point of building at your side.

Figure shows the grounding points.

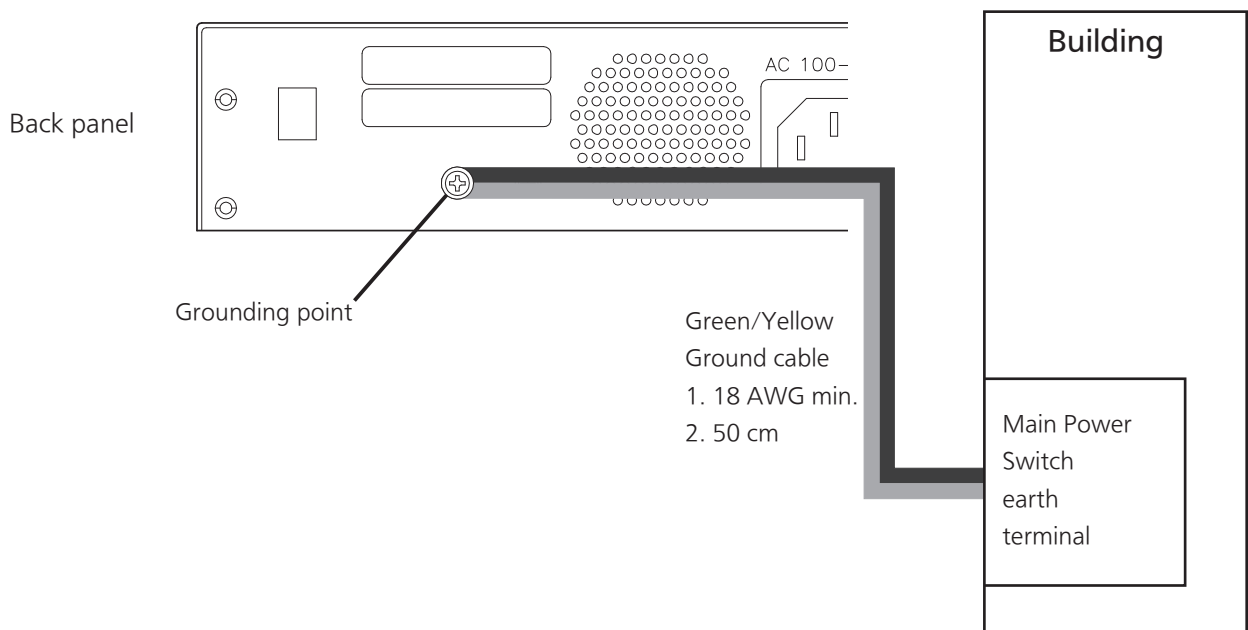

## 3 Installation and Configuration

### 3.2 Mounting on a wall

Use the two wall mount brackets and eight screws (for fixing the wall mount brackets to the Ethernet Switch) supplied with the mount brackets to fix the mount brackets to the four holes on each side of the Ethernet Switch. Then position the front panel of the device so that it is perpendicular and facing upwards, or facing downwards, and secure the device securely to the wall surface with the screws which the customer has prepared.

It is recommended that the screws which are to be used with the screw retainers on the wall have head sizes with diameters of 9.4 mm or greater.

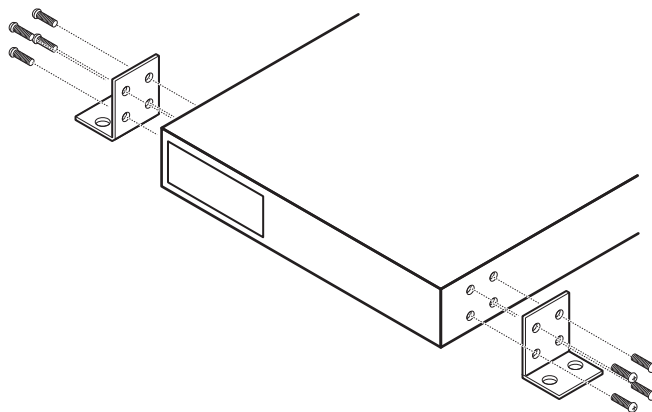
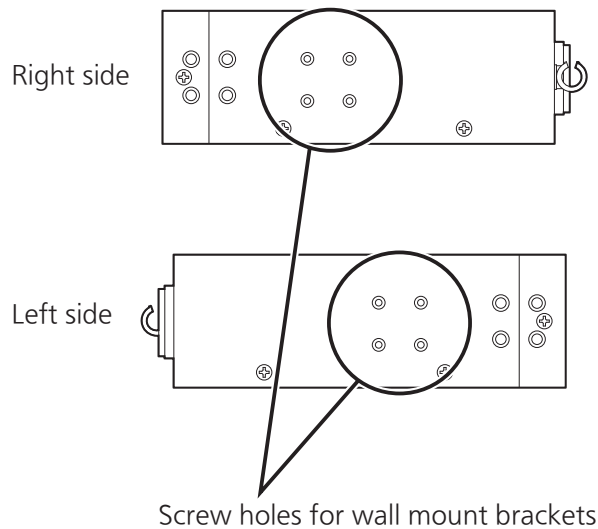

### 3.3 Mounting to rack

Use the two 19-inch rack mount brackets and eight screws (for fixing the rack mount brackets to the Ethernet Switch) supplied with the mount brackets to fix the mount brackets to the four holes on each side of the Ethernet Switch.

Then securely install the Ethernet Switch onto the rack using the four screws (for a 19-inch rack mount) supplied with the mount brackets or the screws supplied with the rack.

Up to two Ethernet Switches can be connected. When connecting two Ethernet Switches and installing them onto a rack, use the two 19-inch rack mount brackets and eight screws (for fixing the rack mount brackets to the Ethernet Switch) supplied with the mount brackets to fix the mount brackets to the four holes on one side of the Ethernet Switches.

Then use the two connection brackets and eight screws (for fixing the connection brackets) supplied with the mount brackets to securely fix the connection brackets to the connection screw holes on the front and back panels, and then install the Ethernet Switches onto the rack.

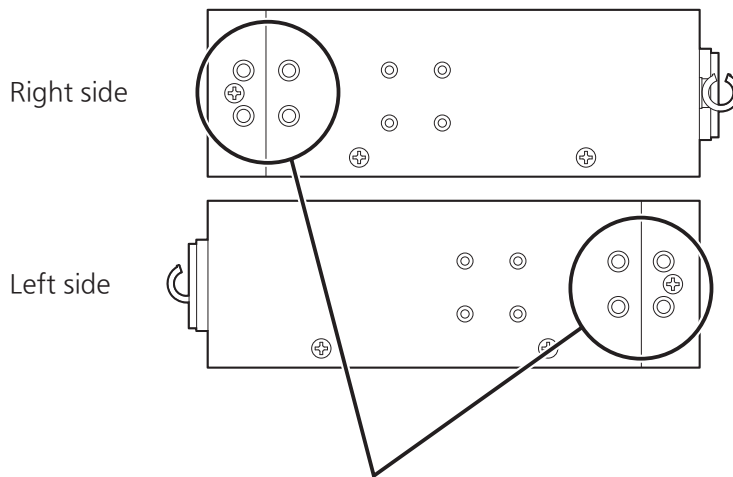

Screw holes for fixing the 19-inch rack mount brackets

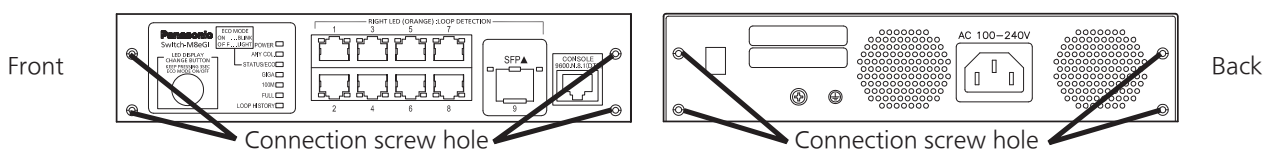

- Installation on a rack (one unit)

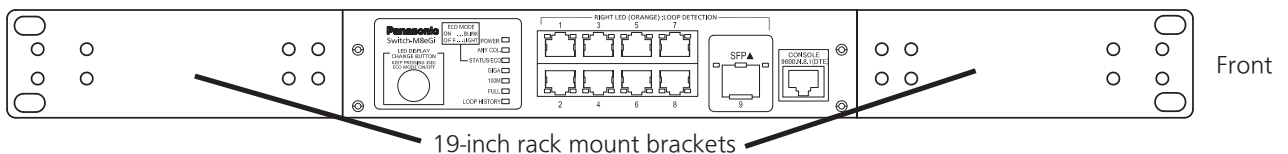

- Installation on a rack (two units connected)

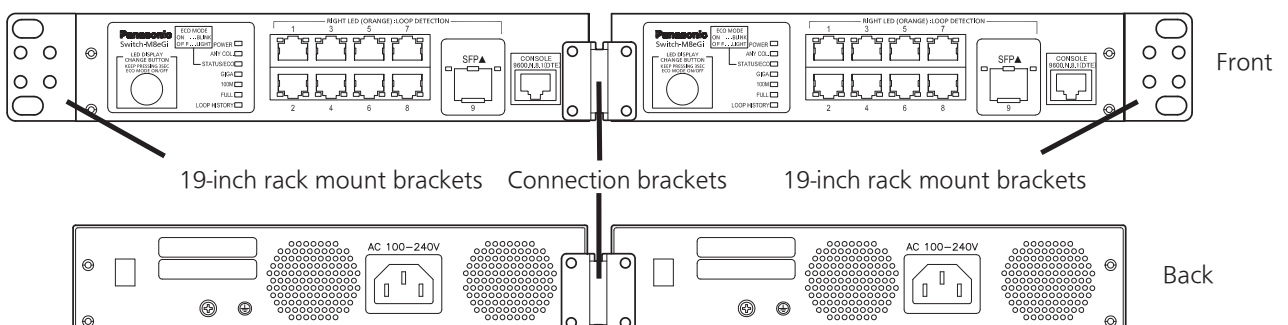

## **3** Installation and Configuration

### **3.4 Configuration of IP address (Basic)**

- (1) Connect this Ethernet Switch and PC with a RJ45–DSub 9-pin console cable and start up the terminal emulator (hyper terminal, etc.).
- (2) Pressing Enter key 3 times opens Login screen. Enter Login name and Password (the default is "manager" for both). **(Screen 1)**
- (3) Main Menu is displayed. **(Screen 2)**  
Press "B" to select [B]asic Switch Configuration. The next hierarchical menu is displayed. **(Screen 3)**
- (4) Press "I" to select System [I]P Configuration. The screen to enter some addresses is displayed. **(Screen 4)**
- (5) Press "I" to set an IP Address, press "M" to set a Subnet Mask, or press "G" to set a Default Gateway. Then enter the specified address. **(Screen 4)**
- (6) After completing the settings, select [Q]uit to previous menu twice to return to Main Menu **(Screen 2)**. Here, select Save Configuration to [F]lash **(Screen 5)** and the command prompt changes to "Save current configuration? (Y/N)." Press "Y" to save the settings.
- (7) From terminals connected to network, confirm that the settings are reflected correctly by executing PING test for entered address.

```

=====
PN28080i Local Management System Version 2.0.1.05
MAC Address: 00-10-40-41-1F-28
=====

Login Menu
Login: █

```

Screen 1

```

PN28080i Local Management System
Main Menu

[G]eneral Information
[B]asic Switch Configuration...
[A]dvanced Switch Configuration...
[S]tatistics
Switch [T]ools Configuration...
Save Configuration to [F]lash
Run [C]LI
[Q]uit

Command> █
Enter the character in square brackets to select option

```

Screen 2

```

PN28080i Local Management System
Main Menu -> Basic Switch Configuration Menu

System [A]dministration Configuration
System [I]P Configuration
S[D]HCP Configuration
[P]ort Configuration Basic
Port Configuration [E]xtend
Port Configuration P[O]wer Saving
[S]ystem Security Configuration
[F]orwarding Database
[T]ime Configuration
A[R]P Table
N[D]P Table
[Q]uit to previous menu

Command> █
Enter the character in square brackets to select option

```

Screen 3

```

PN28080i Local Management System
Basic Switch Configuration -> System IP Configuration Menu

MAC Address: 00-10-40-41-1F-28
IP Address: 192.168.40.31
Subnet Mask: 255.255.255.0
Default Gateway: 0.0.0.0

----- <COMMAND> -----
Set [I]P Address
Set Subnet [M]ask
Set Default [G]ateway
Set IP P[L]arameter
Set [I]Pv6 Address
[Q]uit to previous menu

Command> █
Enter the character in square brackets to select option

```

Screen 4

```

PN28080i Local Management System
Main Menu -> Save Configuration to Flash

Save current configuration? (Y/N)> █
Y for Yes; N for No

```

Screen 5

\* For detailed configuration and management methods, and the settings from the ZEQUO assist Plus and the Web screens, please see the PDF version of the Operating Instructions on Panasonic's website.

# Troubleshooting

If you find any problem, please take the following steps to check.

## ◆ LED

**The POWER LED (Power) is not lit.**

- Check if the power cord is disconnected. Please confirm that the power cord is securely connected to the power port.
- Is the Ethernet Switch used at a temperature between 0 and 60°C?  
Use the Ethernet Switch in its operating temperature range.

**The Port LED is not lit in Status mode.**

- Is the cable correctly connected to the target port?
- Is the cable appropriate to use?
- Is the terminal connected to the relevant port conforming with 10BASE-T, 100BASE-TX, or 1000BASE-T standard?
- Auto-negotiation may have failed.
- Is the correct Port LED display mode selected using the LED display switch button?

**The Port LED (Right) lights in orange.**

- Loop is occurring. By removing the loop, orange LED will be turned off.

**LOOP HISTORY LED Blinks in green.**

- This is to notify that there is a port in which a loop is occurring, or has been removed within 3 days.

## ◆ Communications are slow.

- Are the communication speed and mode settings correct?  
If the proper communication mode signal cannot be obtained, apply half-duplex mode.  
Please reconfirm autonegotiation setting.
- Do not set forced full-duplex for the equipment that the Ethernet Switch is connected to.
- Is not the utilization ratio of the network to which this Ethernet Switch is connected too high?  
Please try to separate the equipment from the network.

## ◆ If communication is disabled

- Are the equipment linked up?  
If Embedded power-saving mode is set to "Full" ,change it to "Half" or "Disabled" .
- Is any Port LED lamp (right) lit in orange?  
If a Port LED lamp (right) is lit in orange, the respective port is shut off by the loop detection/shutoff function. Cancel loop connection under the port and then wait for the period set for the recovery time for automatic recovery for loop detection/shutoff or cancel port shutoff from the setting screen.