

Model Name	GA-ML8TPoE+	Product Specification	401-260893-ID-SP05
Model No.	PN260893-ID		Page 1 of 17

## 1. Summary

GA-ML8TPoE+ is an Ethernet Switch with management function having 10ports of 10/100/1000BASE-T and SFP extension slot, one of which is selectable.  
Ports 1 to 8 support IEEE802.3at/af PoE power supply function.

## 2. Feature

- (1) Ports 1 to 8 are 10/100/1000BASE-T ports corresponding to auto negotiation. Also their speed and communication mode can be switched by configuration. Ports 9 and 10 can be used as a 10/100/1000BASE-T port corresponding to auto negotiation or an SFP extension slot exclusively.
- (2) Ports 1 to 8 can supply power conforming with IEEE802.3at and 802.3af. Supplying power up to 30 W per port, and up to 124 W in total is possible.
- (3) Is equipped with PoE auto reboot function, and monitoring, and the switching of the power supply OFF/ON to ports is possible via Ping, LLDP, and the 3 traffic volume methods.
- (4) Is equipped with silent fan control functions, can be set to match the operating environment temperature and power supply, and be used with any of the fan rpm, "High", "Low" and "Min".
- (5) All twisted pair ports support straight/cross cable auto sensing function. Simply connect devices with straight cables, whether it is a terminal or a network device. (This function does not work if the port communication configuration is set at Fixed or Link Aggregation. Ports 1 to 8 are set at MDI-X. (default))
- (6) Telnet/SSH allows remote configuration changes and verifications of the Ethernet Switch. Remotely configure the PoE settings for each port (Ports 1 to 8).
- (7) The connection status for each port is detected by the power saving mode, and it can suppress the power consumption to required volumes when not linked up. (Factory default: deactivated)
- (8) Rapid Spanning Tree Protocol is supported, allowing to build a system with redundancy.
- (9) The IEEE802.1p compatible QoS function is supported.
- (10) Supports triple authentication that can simultaneously wait on IEEE802.1X authentication, MAC authentication, and WEB authentication via one port, and an authentication network which is matched to the kinds of connection terminals can be constructed.
- (11) Equipped with step authentication functions, and can prevent illegal access of the terminals.
- (12) Since it is equipped with authentication supplicant functions, a more robust security configuration can be configured in combination with the upper switch's IEEE802.1X authentication function.
- (13) Due to the loop detection/shutoff function, a port where loop has occurred can be automatically shut off to prevent loop failures. When a port is shut off and recovered automatically, SNMP trap can be sent to notify the incident to the administrator. Moreover, the port with a loop can be identified by loop notification on the LEDs on the main unit and referring the history of loop on the setting screen.
- (14) The PoE scheduler function enables scheduling of PoE power supply control.
- (15) Supports ZEUQUO assist Plus. Processes from introduction to maintenance can be performed easily.

Date issued	Oct. 31, 2019	<b>Panasonic Electric Works Networks Co.,Ltd.</b>
Date revised	Oct. 31, 2022	

Model Name	GA-ML8TPoE+	Product Specification	401-260893-ID-SP05
Model No.	PN260893-ID		Page 2 of 17

### 3. Rated/Environmental Conditions

3-1. Power supply	AC100-240V, 50/60Hz, 4.0A (with a built-in power supply)
3-2. Power consumption	Normally, Max.152W (15.2W when not supplying power), Min.11.7W
3-3. Operating environment	<p>Temperature: 0 - 50°C Humidity: 20 - 80%RH (no condensation)</p> <p>(Please note) Please note that if the aforementioned conditions are not satisfied, then that may cause fire, electrical shock, malfunctions or misoperations, which are not covered by the warranty. *If it is used beyond the operating environmental temperatures, then the protective devices will start working and the Ethernet Switch power will be shut off. *If the settings for the silent fan control functions are changed, then the upper limit for the operating environmental temperatures may change. For details, check "7-11. The Silent Fan Control Functions".</p>
3-4. Storage environment	<p>Temperature: -20 - 70°C Humidity: 10 - 90%RH (no condensation)</p>
3-5. EMC compliance	<p>CISPR 32 Class A EN 55032 Class A AS/NZS CISPR32 Class A VCCI Class A EN 61000-3-2, EN 61000-3-3 EN 55024 IEC 61000-4-2, IEC 61000-4-3, IEC 61000-4-4, IEC 61000-4-5, IEC 61000-4-6, IEC 61000-4-8, IEC 61000-4-11</p> <p>* Electrical surges (lightning-induced surges in wiring): 10 kV (Depending upon the twisted pair ports, and Panasonic's proprietary evaluations)</p>
3-6. Safety compliance	IEC 62368-1 EN 62368-1
3-7. Environment compliance	RoHS compliant

### 4. Form

4-1. Form and materials/colors	<p>Dimensions : 44mm (Height) × 210mm (Width) × 260mm (Depth) (Excluding protruding sections)</p> <p>Case material : SECC</p> <p>Color : Main unit: Green 03, Front face: Black 03, Face plate label: Black 04</p>
4-2. Mass (Weight)	2,400g

Date issued	Oct. 31, 2019	<b>Panasonic Electric Works Networks Co.,Ltd.</b>
Date revised	Oct. 31, 2022	

Model Name	GA-ML8TPoE+	Product Specification	401-260893-ID-SP05
Model No.	PN260893-ID		Page 3 of 17

## 5. Hardware Specifications

5-1. Interface	<p>Twisted pair port 1-8 :RJ45 connector (*1)  Transmitting and receiving network system :</p> <table border="0"> <tr> <td>IEEE802.3</td> <td>10BASE-T</td> </tr> <tr> <td>IEEE802.3u</td> <td>100BASE-TX</td> </tr> <tr> <td>IEEE802.3ab</td> <td>1000BASE-T</td> </tr> </table> <p>Energy Efficient Ethernet (*2) :IEEE802.3az(LPI)  Transmission speed :10/100/1000Mbps, full/half duplex  Compatible cable :Twisted pair cable  (At least equivalent to EIA/TIA568 category 5e)</p> <p>Maximum transmission distance :100m  Auto-Negotiation :Communication speed and full/half duplex are automatically recognized.  The setting can be fixed to 10Mbps, 100Mbps or 1000Mbps and full duplex or half duplex.</p> <p>PoE power supply function :IEEE802.3af/at  Up to 124 W of power can be supplied to ports 1 to 8 in total.  (Maximum power supplied to a port: 30 W)</p> <p>PoE power supply method :Alternative A  (Cable signal lines 1, 2, 3, and 6 are used.)</p> <p>Twisted pair port 9,10 :RJ45 connector  Transmitting and receiving network system :</p> <table border="0"> <tr> <td>IEEE802.3</td> <td>10BASE-T</td> </tr> <tr> <td>IEEE802.3u</td> <td>100BASE-TX</td> </tr> <tr> <td>IEEE802.3ab</td> <td>1000BASE-T</td> </tr> </table> <p>energy efficient Ethernet :IEEE802.3az(LPI)  Transmission speed :10/100/1000Mbps, full/half duplex  Compatible cable :Twisted pair cable  (At least equivalent to EIA/TIA568 category 5e)</p> <p>Maximum transmission distance :100m  Auto-Negotiation :Communication speed and full/half duplex are automatically recognized.  The setting can be fixed to 10Mbps, 100Mbps or 1000Mbps and full duplex or half duplex.</p> <p>*1 Embedded power saving mode detects the connection status automatically and saves power consumption to minimum.  *2 Energy Efficient Ethernet (EEE) conforming to IEEE802.3az (LPI).  When there is no data transmission at link up, the energy-saving state automatically starts so that power consumption can be reduced on each port.</p> <p>SFP extension slot 9,10  Transmitting and receiving network system: IEEE802.3z 1000BASE-X  * Select either of RJ45 or SFP for use  SFF-8472 (DMI:Diagnostic Monitoring Interface)  * Optional Accessories : 1000BASE-SX SFP Module(i) (PN54022-ID)  1000BASE-LX SFP Module(i) (PN54024-ID)</p>	IEEE802.3	10BASE-T	IEEE802.3u	100BASE-TX	IEEE802.3ab	1000BASE-T	IEEE802.3	10BASE-T	IEEE802.3u	100BASE-TX	IEEE802.3ab	1000BASE-T
IEEE802.3	10BASE-T												
IEEE802.3u	100BASE-TX												
IEEE802.3ab	1000BASE-T												
IEEE802.3	10BASE-T												
IEEE802.3u	100BASE-TX												
IEEE802.3ab	1000BASE-T												

Date issued	Oct. 31, 2019	<b>Panasonic Electric Works Networks Co.,Ltd.</b>
Date revised	Oct. 31, 2022	



## 5. Hardware Specifications

5-4. LED display	<p>(1) POWER (Power) LED  Green Light : Power is ON  Off : Power is OFF</p> <p>(2) PoE LIM. LED (PoE limit)  For silent fan control high-speed (High) * For factory default, or low-speed (Low2)  Off : Supplying power in the range from 0 to 109 W.  Green Light : Supplying power in the range from 109 to 124 W.  Orange Blink : A single port's power supply is exceeding the upper limit, or the total power supply of the Ethernet Switch is exceeding 124 W.  For silent fan control low-speed (Low1), or Min-speed (Min)  Off : Supplying power in the range from 0 to 47 W.  Green Light : Supplying power in the range from 47 to 62 W.  Orange Blink : A single port's power supply is exceeding the upper limit, or the total power supply of the Ethernet Switch is exceeding 62 W.</p> <p>(3) TEMP LED (Temperature sensor)  Green Light : The system is normally operating.  Orange Blink : The temperature exceeded the set threshold of the internal temperature sensor.  Set threshold of the internal temperature sensor: 68°C/72°C(*1)  (factory default)  *1 : Applied to the products with S/N 2AE94100001 or higher</p> <p>(4) FAN (Fan sensor) LED  Green Light : The system is normally operating.  Orange Blink : Fan failure</p> <p>(5) STATUS/ECO LED (Status/ECO mode)  Green Light : Operating in status mode.  Green Blink : Operating in ECO mode.  All port LEDs are turned off.  Orange Light : Starting.  Orange Blink : Malfunction (Contact the seller).</p> <p>(6) GIGA LED (GIGA mode)  Green light : Operating in GIGA mode.</p> <p>(7) Full LED (DUPLEX mode)  Green light : Operating in DUPLEX mode.</p> <p>(8) LOOP HISTORY LED (Loop History mode)  Green Light : Operating in loop History mode  Green Blink : Loop is occurring,  or occurred within the last 3 days.  Off : No loop detection.</p>	<p>Display of each port is refer to table 1 of page 6 .</p>
------------------	---	---

## 5. Hardware Specifications

### 5-4. LED display

You can display the following items using the LED display change button.  
 Display for the connection with a connected terminal (Status mode), Display for the 1000 Mbps transmission rate (GIGA mode), Display for the full-duplex or half-duplex transmission system (DUPLEX mode), Display for ports with a loop history (Loop history mode), All port LED lamps can be turned OFF (ECO mode).

The mode at the start is called “Base mode”.

There are two types of Base modes : Status mode (factory default setting) and ECO mode.

You can change the Base mode by holding down the LED display change button (for at least 3 sec).

When the Base mode is changed normally, all STATUS/ECO, GIGA and FULL LED lamps light up at the same time. When you release the button, the Base mode is changed to the selected mode.

If the mode is changed to the GIGA mode, DUPLEX mode, or Loop History mode and the LED display switch button is not used for one minute or longer, the mode automatically returns to a Base mode (Status mode or ECO mode).

The Base mode is maintained even after the power is turned OFF.

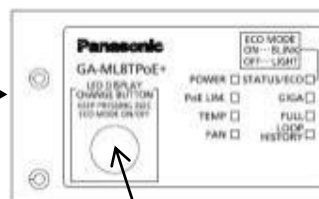
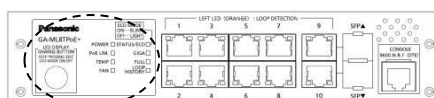

LED display change button

Switch two types of Base mode s and their LEDs in the following way:

When Base mode is Status mode (factory default setting)

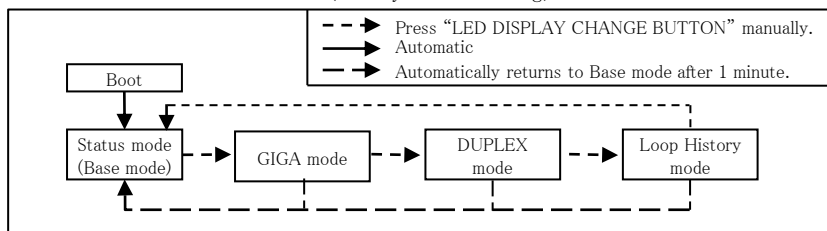

When Base mode is ECO mode

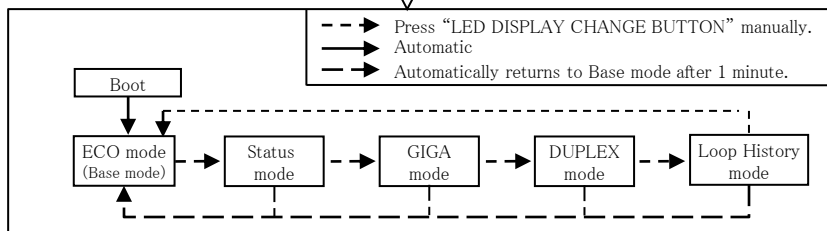

LED lamps for each mode and LED lamps for ports 1 to 10 correspond as the following. (Table 1)

## 5. Hardware Specifications

<p>5-4. LED display</p>	Table 1			
	Port LED	Display mode	Behavior	Description
	Left	STATUS/ECO	Green Light	Link is established. Transmitting and receiving data. It is shut off via the loop detection and shut off function/storm control or the BPDU guard It is sending and receiving just the control packet. No device connected or the ECO mode is set.
			Green Blink	
			Orange Light	
			Orange Blink	
	Right	GIGA	Green Light	Link is established at 1000 Mbps. Link is established at 100 Mbps or 10 Mbps, or no device is connected.
Off				
FULL			Green Light	
Off				
Right	LOOP HISTORY	Green Light	Loop has been detected within the last 3 days. No loop detection history.	
		Off		
Right	/	Green Light	PoE are being supplied power. Single port overload. Also, an overload of the Ethernet Switch occurs, and the ports are displayed which cannot be supplied power. Power is not being supplied, or the PoE receiving equipment are not connected. also, it is set in the ECO mode.	
		Orange Blink		
Right	/	Off		
		Off		

5-5. Cascade connections

Port 1-10 corresponding to the Auto MDI / MDI-X  
(Allowed change by the setting for the application)  
Ports 1-8 are set to "Disable" at factory default setting.

5-6. FAN

installed

Model Name	GA-ML8TPoE+	Product Specification	401-260893-ID-SP05
Model No.	PN260893-ID		Page 8 of 17

## 6. Software Specifications

6-1. Configuration	Control parameters can be set by the following procedures: (1) Configuration from an asynchronous terminal connected to the console port. (2) Configuration from a remote terminal connected via TELNET and SSH. (3) It can be set from a remote terminal according to the Web screen.
6-2. Ethernet Switch Control	ZEQUO assist Plus can confirm the management/operation status of Ethernet Switch.  Ethernet Switch can be controlled by the following procedures: (1) Control from an asynchronous terminal connected to the console port. (2) Control from a remote terminal using SSH/TELNET and TCP/IP network connection (3) Control using SNMP Manager The Ethernet Switch operation status can be checked using the following functions. (1) Internal temperature sensor function (2) Function to display the CPU usage and memory usage (3) SFP module status checking function (DDM: Digital Diagnostic Monitoring)
6-3. Rebooting	The system can be reset from the software in the following three modes: (1) Warm start. (2) Reset back to the factory default settings.
6-4. Supported Agent	Management protocol :SNMP v1/v2c /v3 (RFC 1157, RFC 1901, RFC 3411, RFC 3412, RFC 3413, RFC 3414, RFC 3415, RFC 3416) TELNET (RFC 854, RFC 855) SSH v2 (RFC 4252, RFC 4253, RFC 4254, RFC 4716, RFC4419) Data transfer protocol :TFTP (RFC 783, RFC 1350)
6-5. Supported MIB	RFC1213-MIB(MIB II) (RFC 1213) (※1) BRIDGE-MIB (RFC 4188) (※2) SNMPv2-MIB (RFC 1907) RMON-MIB (RFC 2819) only etherStatsTable SNMP-FRAMEWORK-MIB (RFC 2571) SNMP-MPD-MIB (RFC 2572) SNMP-NOTIFICATION-MIB (RFC 2573N) SNMP-TARGET-MIB (RFC 2573T) SNMP-USER-BASED-SM-MIB (RFC 2574) SNMP-VIEW-BASED-ACM-MIB (RFC 2575) SNMP-COMMUNITY-MIB (RFC 2576) IP-MIB (RFC 4293) (※3) IF-MIB (RFC 2863) excluding IfMIB IEEE8021-PAE-MIB excluding dot1xPaeSuppllicant  *1 Excluding following item At , ipRouteTable, icmp, egp *2 Excluding following item dot1dStp, dot1dSr, dot1dStatic *3 Excluding following item ipDefaultRouterTable, ipv6RouterAdvertTable
6-6. System log	Maximum number to be kept: 10,000 Transfers system logs to the Syslog server (IPv4/IPv6)

Date issued	Oct. 31, 2019	<b>Panasonic Electric Works Networks Co.,Ltd.</b>
Date revised	Oct. 31, 2022	

Model Name	GA-ML8TPoE+	Product Specification	401-260893-ID-SP05
Model No.	PN260893-ID		Page 9 of 17

## 6. Software Specifications

<p>6-7. Loop detection</p>	<p>Turns on the port LED with a orange light when a loop occurs in the corresponding port. At this time, the relevant port automatically shuts down (default setting: 60 sec.) to prevent loop from occurring .During loop is occurring, or if loop has occurred within the latest 3 days, LOOP HISTORY LED blinks to notify this.</p> <ul style="list-style-type: none"> <li>· Loop detection setting <ul style="list-style-type: none"> <li>Enabled (factory default setting)</li> <li>Enabled/disabled can be switched by configuring a setting using the console.</li> <li>The setting is kept even when the power is turned OFF.</li> </ul> </li> <li>· Loop detection port <ul style="list-style-type: none"> <li>Enabled: Ports 1 to 8 (factory default setting)</li> <li>Disabled: Ports 9 and 10 (factory default setting)</li> </ul> </li> <li>· Loop shutoff time <ul style="list-style-type: none"> <li>60 to 86,400 sec. (Factory default setting: 60 sec.)</li> <li>The Set Time Port LED lights up orange and the port shuts off.</li> </ul> </li> <li>· Loop history retention time <ul style="list-style-type: none"> <li>3 days</li> <li>The LOOP HISTORY LED blink for three days.</li> <li>The Port LED also remains lit for three days after the loop is eliminated.</li> </ul> </li> </ul> <p>Loop shutoff mode has the following 2 types of modes.</p> <ul style="list-style-type: none"> <li>•Block mode (factory default setting) <ul style="list-style-type: none"> <li>When loops are detected, the port statuses are automatically blocked, and just the specified packets which include the loop detection packets will be transmitted and received.</li> </ul> </li> <li>•Shut-down mode <ul style="list-style-type: none"> <li>When loops are being detected, the ports will be automatically linked down, and none of the packets will be transmitted and received.</li> <li>*Just the loop detection packets from 30 seconds before the set restoration times will automatically be transmitted and received.</li> </ul> </li> </ul>
<p>6-8. Others</p>	<p>Syslog Client (Transfers system logs to the Syslog server.)  TFTP Client (Upgrades the software and saves/loads configuration information.)  SNTP Client  TELNET Client  DHCP Client  LLDP  LLDP-MED  DNS Resolver  DHCP Snooping  DDM  Statistics  sFlow  Ethernet OAM  CFM  UDLD (Scheduled to be supported)</p>

Date issued	Oct. 31, 2019	<b>Panasonic Electric Works Networks Co.,Ltd.</b>
Date revised	Oct. 31, 2022	

Model Name	GA-ML8TPoE+	Product Specification	401-260893-ID-SP05
Model No.	PN260893-ID		Page 10 of 17

## 7. Layer 2 Switching Functions

7-1. Spanning Tree	IEEE 802.1D Spanning Tree Protocol, Rapid Spanning Tree Protocol IEEE 802.1Q Multiple Spanning Tree Protocol BPDU guard
7-2. VLAN	IEEE802.1Q Private VLAN MAC-based VLAN Subnet based VLAN Protocol-based VLAN Number of VLAN registrations: 4,094 (including default) Asymmetric VLAN Voice VLAN (LLDP-MED) Dynamic VLAN Guest VLAN Internet mansion function
7-3. Link aggregation	IEEE802.3ad Link Aggregation function (LACP/Manual) Up to 5 groups can be created (up to 8 ports per group).
7-4. SPAN,RSPAN	Subject port traffic can be copied and transmitted to designated ports (multiple subject ports can be designated) Remote switching packets can be monitored via RSPAN.
7-5. Port grouping	Members of the port group can communicate only among member ports in the same group. (Number of group registrations: 256)
7-6. QoS	IEEE802.1p 8 levels of Priority Queue supported Scheduling Method: Strict Priority Queuing (SPQ: Strict priority queuing) Weighted Round Robin (WRR: Weighted round robin scheduling) Weighted Deficit Round Robin (WDRR: Weighted Deficit Round Robin scheduling)
7-7. Authentication Function	IEEE802.1X Port-based authentication Mac-based authentication using IEEE 802.1X Dynamic VLAN function using IEEE 802.1X Guest VLAN using IEEE 802.1X (EAP-MD5/TLS/PEAP Authentication method) IEEE802.1X supplicant Force Authorized MAC Address Configuration EAP Packet Forwarding function (Enable/disable EAP transmission can be specified for each port.) MAC authentication WEB authentication Triple authentication (*1) Step authentication (*2) *1 IEEE802.1X MAC-based/MAC/WEB authentication can be simultaneously *2 2 authentications can be combined in phases MAC-WEB authentication MAC-802.1X authentication 802.1X-WEB authentication
7-8. PoE power supply function	IEEE802.3af/at power supply function. Up to 124 W of power can be supplied to ports 1 to 8 in total. (Maximum power supplied to a port: 30 W) Supply method : Alternative A (Cable signal lines 1, 2, 3, and 6 are used.)
7-9. PoE scheduler function	PoE power supply control can be scheduled. The setting can be configured by the month, week, day or specific date. The maximum number of schedules to be registered: 32
7-10. PoE auto reboot function	Monitoring, and the switching of the power supply OFF/ON to ports is possible via Ping, LLDP, and the 3 traffic volume methods.

Date issued	Oct. 31, 2019	<b>Panasonic Electric Works Networks Co.,Ltd.</b>
Date revised	Oct. 31, 2022	

## 7. Layer 2 Switching Functions

7-11. Silent fan control	<p>The fan rpm can be set in accordance with the usage environments. If the fan rpm are set, the available power supply will be automatically restricted. If the fan rpm (Fan Speed) are set to Low1, or Min, the device's overall available power supply (Power Budget) will be automatically restricted, and it can be used with the fan noise reduced.</p> <table border="1"> <thead> <tr> <th>Fan Speed</th> <th>Operating environment temperature</th> <th>Available PoE power</th> <th>Comments</th> </tr> </thead> <tbody> <tr> <td>High</td> <td rowspan="2">0-50°C</td> <td>124W</td> <td>Factory default</td> </tr> <tr> <td rowspan="2">Low (Low1)</td> <td>62W</td> <td></td> </tr> <tr> <td>(Low2)</td> <td rowspan="2">0-40°C</td> <td>124W</td> <td></td> </tr> <tr> <td>Min</td> <td>62W</td> <td></td> </tr> </tbody> </table>	Fan Speed	Operating environment temperature	Available PoE power	Comments	High	0-50°C	124W	Factory default	Low (Low1)	62W		(Low2)	0-40°C	124W		Min	62W	
Fan Speed	Operating environment temperature	Available PoE power	Comments																
High	0-50°C	124W	Factory default																
Low (Low1)		62W																	
	(Low2)	0-40°C	124W																
Min	62W																		
7-12. Ring redundant protocol	Redundancy is enabled by ring configuration. (Up to 5 group can be registered.)																		
7-13. Multicast	IGMP snooping (IGMPv1/v2/v3) function (can be up to 1,024 groups of registration) IGMP Querier function MLD snooping (MLDv2) function (can be up to 1,024 groups of registration) Multicast filtering function																		
7-14. Access control	Access control can be controlled by the following parameters: (1) IP address, IPv6 address (Source or Destination) (2) MAC address (Source or Destination) (3) TCP/UDP port number (Source or Destination) (4) VLAN ID (5) IEEE 802.1p Priority (6) DSCP, DSCP6 (7) Protocol (8) ICMP type (9) TCP SYN Flag																		
7-15. Time setting	SNTP settings, time manual setting																		
7-16. Storm control function	Unknown unicast, Broadcast, Multicast of possible control the storm																		

## 8. WEB Browser-based Control (WEB control screen)

8-1. System Requirements		
8-1-1. WEB Browser	Microsoft Internet Explorer 11	
8-2. Configuration Function		
8-2-1. Switching configuration	Administration IP Address SNMP Sntp Port System Security ID/Password Change Forwarding Database(FDB) Time(Sntp) LLDP VLAN Link Aggregation QoS Storm Control Access control ARP entry manual registration Port grouping Port monitoring Port counter	Authentication IGMP Querier IGMP Snooping Spanning Tree MSTP (Multiple Spanning Tree) Loop Detection DDM Ring protocol PoE Statistics System Log Syslog Transmission
8-3. Monitoring Configuration	Firmware upgrade, Reboot, Save current configuration, file transfer, Ping execution	

## 9. Connector Pin Arrangement

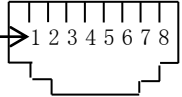
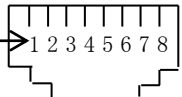
9-1. Port 1 - 10										
Status	Pin No.	1	2	3	6	4	5	7	8	
MDI-X	Signal	BL_DB+	BL_DB-	BL_DA+	BL_DA-	BL_DD+	BL_DD-	BL_DC+	BL_DC-	
MDI	Signal	BL_DA+	BL_DA-	BL_DB+	BL_DB-	BL_DC+	BL_DC-	BL_DD+	BL_DD-	
9-2. Console port										
Pin No.	Signal	Pin No.	Signal							
1	NC	5	GND							
2	NC	6	RXD							
3	TXD	7	NC							
4	GND	8	NC							

Model Name	GA-ML8TPoE+	Product Specification	401-260893-ID-SP05
Model No.	PN260893-ID		Page 13 of 17

## 10. Installation Procedures and Accessories

10-1. Installation Procedures	(1) Mounting to rack	
10-2. Accessories	(1) Installation Guide (English)	:1
	(2) Rubber foot	:4
	(3) Rack mount bracket (for 19-inch rack)	:2
	(4) Connection bracket (for connection two Switching Hubs)	:2
	(5) Screw (for 19-inch rack)	:4
	(6) Screw (for fixing the mount brackets to the Switching Hub)	:8
	(7) Screw (for fixing the connection bracket)	:8
	(8) Power cord (CEE7/7)(*)	:1
	* The attached power cord is dedicated for AC 100 - 240 V use.	

## 11. Optional Accessories

11-2. 1000BASE-SX SFP Module(i) (Model No.:PN54022-ID)	Fiber optic port connector type :LC connector (Duplex) Standards :IEEE802.3z 1000BASE-SX Transmission speed :1000Mbps, full duplex Compatible cable :Fiber cable 50/125 $\mu$ m Multi Mode Fiber 62.5/125 $\mu$ m Multi Mode Fiber Maximum transmission distance :550 m at 50/125 $\mu$ m 220 m at 62.5/125 $\mu$ m Operating Temperature :0 - 60°C
11-3. 1000BASE-LX SFP Module(i) (Model No.:PN54024-ID)	Fiber optic port connector type :LC connector (Duplex) Standards :IEEE802.3z 1000BASE-LX Transmission speed :1000Mbps, full duplex Compatible cable :Fiber cable 10/125 $\mu$ m Single Mode Fiber 50/125 $\mu$ m Multi Mode Fiber 62.5/125 $\mu$ m Multi Mode Fiber Maximum transmission distance :10 km when Single Mode Fiber is used 550 m when Multi Mode Fiber is used Operating Temperature :0 - 60°C

Date issued	Oct. 31, 2019	<b>Panasonic Electric Works Networks Co.,Ltd.</b>
Date revised	Oct. 31, 2022	

Model Name	GA-ML8TPoE+	Product Specification	401-260893-ID-SP05
Model No.	PN260893-ID		Page 14 of 17

## 12. Prohibitions when Using the Product to Guarantee Safety

Denotes that “Death or serious injuries might be sustained”.

The manufacturer assumes no responsibility for any problems occurring when the following conditions are not satisfied.

Observe the following items when using the product.

- (1) Do not use power supply other than AC 100 – 240 V.  
Deviation could lead to fire, electric shock, and/or equipment failure.
- (2) Do not handle this Ethernet Switch and connection cables during a thunderstorm.  
Deviation could lead to electric shock.
- (3) Do not disassemble and/or modify this Ethernet Switch.  
Deviation could lead to fire, electric shock, and/or equipment failure.
- (4) Do not damage the power cord. Do not bend too tightly, stretch, twist, bundle with other cord, pinch, put under a heavy object and/or heat it.  
Damaged power cord could lead to fire, short, and/or electric shock.
- (5) Do not unplug nor plug in the power plug with wet hands.  
Deviation could lead to electric shock, and/or equipment failure.
- (6) Do not insert, nor drop foreign objects such as metal or combustible things into the inside through the openings, twisted pair port, console port and SFP extension slot.  
Deviation could lead to fire, electric shock, and/or equipment failure.
- (7) Do not store or use the Ethernet Switch in places where it might get splashed with liquids such as water, in places with a lot of humidity, in places with conductive dust, or in places where there are corrosive and combustible gases.  
Deviation could lead to fire, electric shock, and/or equipment failure.
- (8) Do not store or use the Ethernet Switch in places where it will be exposed to direct sunlight or high temperature.  
The temperature inside will rise, which may cause fire.
- (9) Do not store or use the Ethernet Switch in places where there are lots of vibrations and impacts, or in unstable areas.  
it might fall, which may cause injuries and/or equipment failure.
- (10) Do not put the Ethernet Switch into fire.  
Deviation could lead to explosion and/or fire.
- (11) Do not use the Ethernet Switch in dusty environments such as on floors, underneath floors, the backside of ceilings, or wiring panels.  
Do not use the Ethernet Switch in very dusty areas such as in floors, underneath floors, the backside of ceilings, or wiring panels. Deviation could lead to fire, electric shock, and/or equipment failure. It is recommended that the Ethernet Switch be operated in environments such as the inside of racks where it is difficult for dust to be generated.

Date issued	Oct. 31, 2019	<b>Panasonic Electric Works Networks Co.,Ltd.</b>
Date revised	Oct. 31, 2022	

Model Name	GA-ML8TPoE+	Product Specification	401-260893-ID-SP05
Model No.	PN260893-ID		Page 15 of 17

### 13. Cautions when Using the Product to Guarantee Safety

Denotes that “Minor injuries might be sustained, or property damage might occur”.

The manufacturer assumes no responsibility for any problems occurring when the following conditions are not satisfied.

Observe the following items when using the product.

- (1) Use the bundled power cord (AC 100 - 240 V specifications).  
Deviation could lead to electric shock, malfunction, and/or equipment failure.
- (2) Unplug the power cord in case of equipment failure.  
Deviation, such as keeping connected for a long time, could lead to fire.
- (3) Be sure to connect the ground cable.  
Otherwise this might cause electrical shocks, misoperations and malfunctions.  
Connect the Ethernet Switch via the supplied power cord to the outlet which is connected to the ground.  
If the outlet is not connected to a ground, connect the ground cable to the ground terminal screw.
- (4) Connect the power cord firmly to the power port.  
Otherwise this might cause electrical shocks and malfunctions.
- (5) Unplug the power cord if the STATUS/ECO LED (Status/ECO mode) or FAN LED (Fan sensor) blinks in orange (system fault).  
Deviation, such as keeping connected for a long time, could lead to fire.
- (6) Handle the Ethernet Switch carefully so that fingers or hands may not be damaged by twisted pair port, SFP extension slot, console port or power cord hook block.
- (7) If the device is going to be mounted onto a rack, use the 2 installation brackets(for 19-inch rack mounting) which include the 19 inch rack mounting brackets (for 1 rack) and the 8 screws (for the rack installation brackets and for the main unit connections), and install the installation brackets into each of the 4 horizontal holes in the device, then securely secure it and set it up.  
If it is not firmly secured, then deviation could lead to falling, injury and/or equipment failure.
- (8) Up to two Ethernet Switches can be connected by using the connection brackets and connection bracket screws.  
Attach the connection brackets to the connection bracket screw holes on the front and back panels to securely fix the Switching Hubs before installation.  
If the Ethernet Switches are not fixed securely, they may fall, leading to injury and/or equipment failure.
- (9) Check whether the optical fiber cable connectors are contaminated with dust, etc.  
This might cause the optical signal to not be transmitted normally, and cause misoperations and malfunctions. If they are contaminated, make sure to clean them off, then connect them to the optical fiber ports.
- (10) This Ethernet Switch is to be periodically serviced in order to maintain its performance.  
Please choose a product administrator, and have them be sure to implement periodic maintenance. When doing maintenance, check the inspection chart that is posted on our website which has the requisite items listed on it.
- (11) When using this Ethernet Switch to design systems, use it after applying appropriate measures such as setting up redundant configurations.  
Communications failures might be generated due to causes such as malfunctions or misoperations while the Ethernet Switch is being used.
- (12) When using this Ethernet Switch for applications which require extremely high reliability, be careful to expend all possible means to ensure safety and reliability.  
This Ethernet Switch was not designed nor manufactured with the intention that it be used for applications (in use with railways, aviation, and medical care, etc. whereas the influence rate due to communications failures is extremely high in regard to systems that directly affect systems and human lives) which require extremely high reliability.

Date issued	Oct. 31, 2019	<b>Panasonic Electric Works Networks Co.,Ltd.</b>
Date revised	Oct. 31, 2022	

Model Name	GA-ML8TPoE+	Product Specification	401-260893-ID-SP05
Model No.	PN260893-ID		Page 16 of 17
<p>(13) Be aware of glitches which are caused in the usage environments such as age-related degradation, etc. This may vary depending upon conditions such as utilization rates and usage environments, but performance might decrease due to the age-related degradation, etc. of components. It is recommended that this Ethernet Switch be replaced about five years after it has been installed.</p> <p>(14) Be careful in regards to environmental restrictions whereby the Ethernet Switch can be used. Please isolate the business power lines and communications lines. Isolate distribution lines and other distribution lines, and low current power lines, optical fiber cables, metallic water conduits, and gas conduits, etc. Noise may be generated in the communications lines which might cause communications glitches.</p> <p>(15) Do not connect any other devices except for 10BASE-T/100BASE-TX/1000BASE-T devices to the twisted pair ports. Deviation could lead to equipment failure.</p> <p>(16) Do not insert any other modules into the SFP expansion slots except for our optional SFP modules (PN54022/PN54024). Deviation could lead to equipment failure. Check our website for the latest information on supported SFP modules.</p> <p>(17) Do not connect the console ports with any other device except for Serial communication terminal. Deviation could lead to equipment failure.</p> <p>(18) To connect a power receiving equipment supporting IEEE802.3at to this Ethernet Switch, use a cable rated Cat5e or higher. Using other cables may result in heat generation, ignition, and/or equipment failure.</p> <p>(19) It is strongly recommended that a lightning arrester (SPD) be installed on the twisted pair port side and the power supply side of this Ethernet Switch. Malfunctions might be caused due to overcurrent and overvoltage due to the effects of lightning strikes.</p>			
Date issued	Oct. 31, 2019	<b>Panasonic Electric Works Networks Co.,Ltd.</b>	
Date revised	Oct. 31, 2022		

Model Name	GA-ML8TPoE+	Product Specification	401-260893-ID-SP05
Model No.	PN260893-ID		Page 17 of 17

#### 14. Basic Instructions for the Use of This Product

- (1) For inspection and/or diagnosis, consult the retailer.
- (2) Use commercial power supply from a wall socket, which is close and easily accessible to this Ethernet Switch.
- (3) Unplug the power cord when installing or moving this Ethernet Switch.
- (4) Unplug the power cord when cleaning this Ethernet Switch.
- (5) Use this Ethernet Switch within the specifications. Deviation could lead to malfunction.
- (6) Do not touch the twisted pair cable modular metal terminals which are connected to RJ45 connectors (twisted pair ports) or the connectors, nor place them near electrically-charged objects. Static electricity could lead to equipment failure.
- (7) Do not put the modular plug of the connected twisted pair cable on objects that can carry static charge, such as carpet. Do not place it in the proximity. Static electricity could lead to equipment failure.
- (8) Do not put a strong shock, including dropping, to this Ethernet Switch. Deviation could lead to equipment failure.
- (9) Before connecting a console cable to the console port, discharge static electricity, for example by touching metal appliance (do not discharge by touching this Ethernet Switch).
- (10) Please use this Ethernet Switch in place where ambient temperature is from 0 to 50°C and, do not store and/or use this Ethernet Switch in the environment with the characteristics listed below. (Store and/or use this Ethernet Switch in the environment in accordance with the specification.)
  - High humidity. Possible spilled liquid (water).
  - Dusty. Possible static charge (such as carpet).
  - Under direct sunlight.
  - Possible condensation. High/low temperature exceeding the specifications environment.
  - Strong vibration and/or strong shock.

Failure to satisfy the conditions above may result in a fire, electric shock, equipment failure, and/or malfunction. Such events are not covered by the warranty.

(\*) If it is used beyond the operating environmental temperatures, then the protective devices will start working and the Ethernet Switch power will be shut off.
- (11) Do not block the ventilator of the Ethernet Switch. Blocked ventilator induces the heat accumulation inside, causing equipment failure and/or malfunction.
- (12) Operation is not guaranteed if a module other than the optional SFP extension modules (PN54022-ID/PN54024-ID) is inserted into the SFP extension slot. For the latest information about compatible SFP extension modules, check our website.
- (13) When using two Ethernet Switches, do not stack them. When you place them side by side, allow for a space of 20 mm or more between them. This space is not necessary if you use supplied connection brackets.
- (14) When Ethernet Switches mounting to rack, leave a minimum of 20mm space between them.

Date issued	Oct. 31, 2019	<b>Panasonic Electric Works Networks Co.,Ltd.</b>
Date revised	Oct. 31, 2022	